

**APPENDIX 11**  
**TO THE GENERAL CONTRACT OF USE**  
**FOR WAGONS**

**Inscriptions and signs on wagons**

## Contents

Point	Subject	Page
1	Introduction – General provisions	4
2.1	Wagon number, country of registration, keeper, type	5
2.2	Derogation plate	7
2.3	Maintenance plate	9
2.4	Signs indicating load limits	10
2.5	Sign indicating carrying capacity	12
2.6	Signs indicating concentrated loads distributed over supporting surfaces of different lengths	13
2.7	Sign indicating the capacity of tank wagons and cask wagons	17
2.8	Signs indicating the length of load and floor space	18
2.9	Sign indicating the distance between end axles and bogie centres	19
2.10	Sign indicating spark arrestor plates	19
2.11	Additional signs for wagons accepted for running in Great Britain	20
2.12	Sign for ferry ramp angle	21
2.13	Sign for removable wagon accessories	22
2.14	Sign for the inside of wagons: "Do not use nails or wire staples"	24
2.15	Markings for wagons with special fittings (wagons with automatic discharge facility, opening roof, etc.)	24
2.16	Signs for wagons built for running between countries with different track gauges	25
2.17	Sign for bogies fitted with gauge-adjustable axles, nominal gauge 1435 mm (automatic gauge changeover facility according to the UIC leaflet 510-4)	25
2.18	Sign for bogies fitted with gauge-adjustable axles, nominal gauge 1520 mm (automatic gauge changeover facility according to the UIC leaflet 510-4)	26
2.19	Additional signs for wagons accepted for running in Spain and Portugal	27
2.20	Approval plate	28
2.21	Marking of vehicle gauge on wagon	28
3.1	Sign for height of the loading plane for container wagons in unladen state	29
3.2	Signs for combined transport wagons in accordance with IRS 50596-6	30
4.1	Sign for length over buffers	38
4.2	Signs for tare and braked weight	39
4.3	Signs to indicate the changeover device for air brakes - Marking of the braked weight on wagons. Brake type abbreviations	41
4.4	Signs for wagons fitted with composite brake blocks	48
4.5	Sign for wagons fitted with disc brakes	49
5.1	Sign for wagons not authorised to negotiate all shunting humps	50
5.2	Sign for bogie wagons with a distance of over 14.0 m between inner axles and accepted on shunting humps	50
5.3	Sign for wagons that are not authorised to pass through retarders or other shunting and stopping devices in active mode	51
5.4	Sign for wagons not to be loose-shunted	51
5.5	Sign for wagons that must not be fly- or gravity-shunted	52
5.6	Sign for fly and hump shunting not permitted for containers or loaded pocket wagons	52
5.7	Marking for wagons fitted with anti-crash components	53

<b>Point</b>	<b>Subject</b>	<b>Page</b>
5.8	Marking for wagons fitted with long-stroke shock absorbers (shock absorber fitting)	53
5.9	Marking for wagons fitted with projecting tow hooks	54
5.10	Sign for permanently coupled wagon units	54
5.11	Sign for bogie wagons only able to negotiate curves with a radius greater than 35 m	55
5.12	Signs indicating wagons fitted with a train line	55
5.13	Sign for wagons fitted with the automatic coupler	56
5.14	Sign for derailment detectors	56
5.15	Sign for strengthened screw coupling	57
6.1	Sign for wheels able to withstand high thermal stresses	59
6.2	Marking of tyred wheels	59
6.3	Sign for ventilation pipes	60
6.4	Sign for tank wagon tests, coding of tanks and special regulations	60
7.1	Sign indicating points for lifting the wagon body in the workshop	61
7.2	Sign for lifting at 4 points with or without running gear	61
7.3	Sign for lifting or re-railing with or without running gear at one end only or close to the end	62
7.4	Sign for the replacement of springs	62
7.5	Sign Wheel tyre inspection	63
7.6	Sign for inspection periods for temperature-controlled units	64
7.7	Sign for the protection of the inner lining of tank wagons	64
7.8	Signs for privately-owned wagons, unified wagons, standard wagons	65
7.9	Sign for the spare parts	66
8.1	Sign for high voltage warning sign (lightning flash)	67
8.2	Signs for high voltage warning sign (Stop!)	68

## 1 Introduction – General provisions

- 1.1 This appendix describes the inscriptions and signs to be affixed to freight wagons (referred to hereafter as wagons) and indicates where they should be positioned. The inscriptions and signs have been grouped together according to certain processes or operations: the loading and provision of wagons, combined transport (CT), train preparation, shunting, technical inspections, workshops and key warning signs – but are not exclusively assigned to a specific process, specialist department or user.
- 1.2 Wagons must carry inscriptions and signs in specific places. They should be affixed in the language of the wagon keeper, using Latin characters and Arabic numerals.
- The inscriptions and signs must always be clearly visible. They should be placed on the side walls, if possible 1600 mm above rail level (height of the middle of the sign). For wagons without side walls, the inscriptions shall be carried on special boards. For the provisions regarding the mark plates on the tank wagons see **UIC leaflet 573**.
- No other meanings may be assigned to the inscriptions and signs.
- 1.2 Wagons on which the markings and signs are missing or illegible shall be dealt with in accordance with **Appendices 9** and **10**.
- 1.4 Inscriptions and signs other than those listed in this Appendix must be placed on parts of the wagon not occupied by these inscriptions.
- The lower left-hand corner of the side walls is reserved for affixing labels, with the exception of K and M labels.

## 2.1 Wagon number, country of registration, keeper, type

The markings shall be made on the side of the wagon as follows (examples):

31 RIV 80 <u>D</u> -DB 0691 235-2 Tanoos	32 RIV 80 <u>D</u> -BASF 7369 553-4 Zcs	33 RIV 84 <u>NL</u> -ACTS 4796 100-8 Slpss	43 87 <u>E</u> 4273 361-3 Laeks
---	--	---	--

or

33 TEN 84 <u>NL</u> -ACTS 4796 100-8 Slpss	87 TEN 82 <u>D</u> -CFLCA 4978 006-4 Sdmrs	G1	CW
---	---	----	----

or

37 TEN 82 <u>L</u> -CFLCA 4992 009-1 Sdggmrss	81 TEN 82 <u>L</u> -CFLCA 3513 156-7 Rbnpss	GE	Derogation plate
--	--	----	------------------

When the wagon body does not provide sufficient surface area for this layout (flat wagons in particular) the markings shall be made as follows (example):

01	87	3320 644-7
RIV	<u>E</u> -SNCF	Ks

**Position:** on the left of each side wall, or the left of each solebar in the case of high-sided open wagons or on special boards in the case of wagons without side walls (e.g. tank wagons).

**Meaning** (based on the first example):

31	Fitness for interoperability (2 digits)
80	Country in which the wagon is registered (2 digits)
0691	Principal technical characteristics (4 digits)
235	Number of the wagon in its production series (3 digits)
-2	Self-check digit (1 digit)
RIV	The RIV marking on wagons means that the vehicle, in addition to having been approved against the rules in force, also meets the regulations of railway Technical Unity (TU) and the provisions of leaflets in the UIC Code and, as a result, satisfies all regulations applicable for its respective type in international rail traffic. These wagons are fully interoperable
TEN	New wagons which have obtained approval against the TSIs (Technical Specifications for Interoperability). The letters "TEN" (for Trans-European Network) may appear alongside or additional markings indicating the vehicle gauge
<u>D</u>	Country in which the wagon is registered, in this case Germany
DB	Wagon keeper (abbreviation); this information is compulsory if the full name of the company complete with address is not given

- Tanoos Reference to principal technical characteristics of the vehicle:
- T: Letter indicating wagon type (capital letter)
  - anoos: identification letters; lower-case letters describing the principal features for the use of the wagon

**Note:**

1. Further details are given in the Uniform Technical Prescription applicable to Vehicle Numbers and linked alphabetical marking on the bodywork: The Railway Vehicle Marking (UTP Marking), issued by the OTIF.
2. Wagons with more than 8 axles can still carry the RIV sign without satisfying the regulations on maximum load (see point 2.4) provided they meet all the other conditions of this appendix and of GCU **Appendix 9** and have no parts that are liable to encroach the vehicle gauge under any operating circumstances. Exceptions are authorised for these wagons in respect of the position of the markings.
3. For wagons meeting all the requirements of the Wagons TSI WAG, the pictogram is used in conjunction with characters 2 or 3 of the wagon number and the "TEN" marking.



4. For wagons which are basically TSI WAG-compliant, but which deviate in terms of their wheelbase or vehicle gauge, or which are subject to other operating restrictions when used in wagonload traffic, the pictogram is used in conjunction with characters 4 or 8 of the wagon number and the "TEN" marking.



In terms of their initial approval for placing in service, these wagons are subject to the conditions in force in all member states; however, under the OPE TSI specific agreements are to be concluded governing their use on individual member-state infrastructure.

### 2.2 Derogation plate

Figure 1

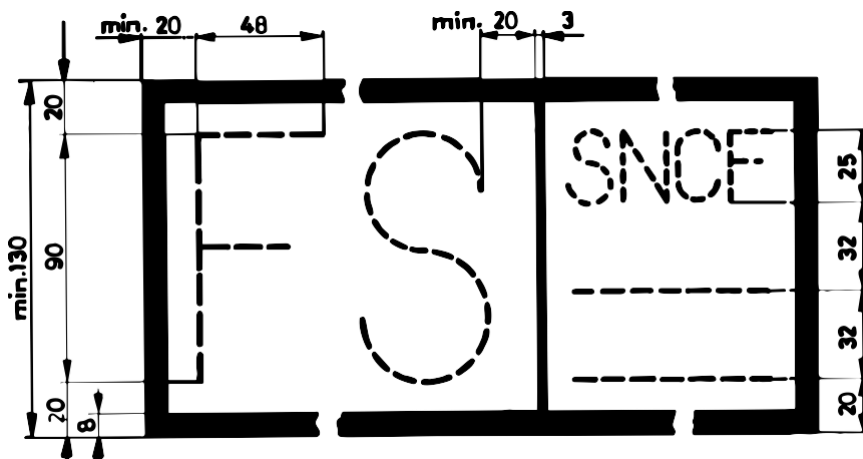

Figure 2

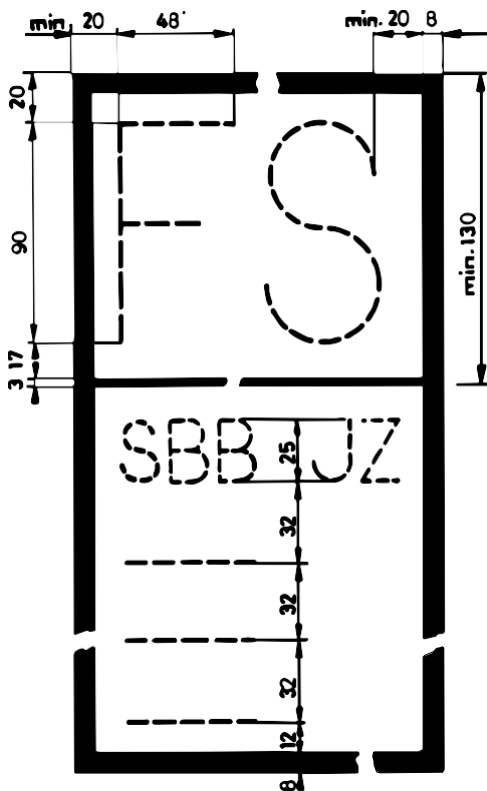

Figure 3

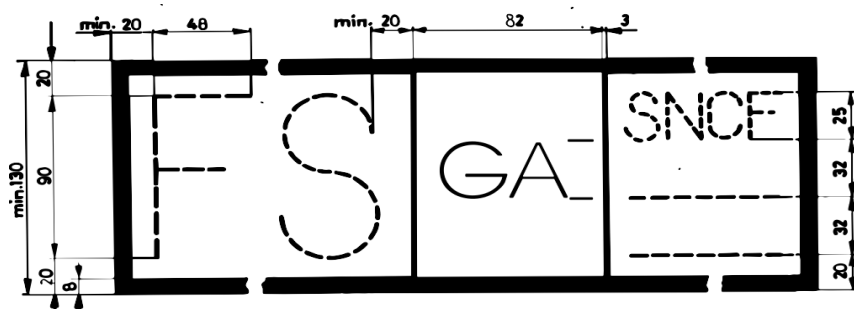
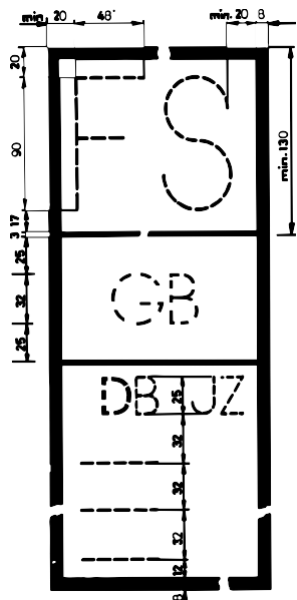

Figure 4



**Position:** On the right of each side wall.

**Meaning:** Because they do not comply fully with the UIC Code, these wagons are not marked with the “RIV” sign. Their use is therefore subject to bi- or multilateral agreements between RUs. The initials of the parties to these agreements are entered in this box and these wagons may only be used by the RUs indicated. As such, they are not fully interoperable.

The letters GA or GB indicate the gauge to which the wagons were built, as described in **UIC leaflet 506**.



### 2.3 Maintenance plate

Figure 1

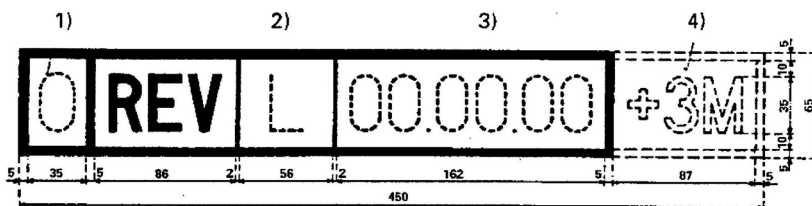

Figure 2

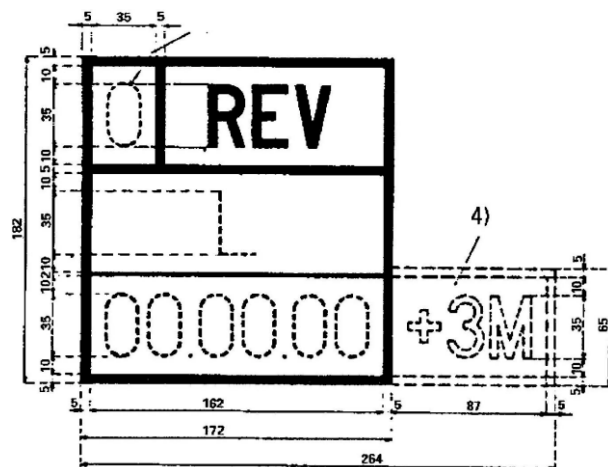

Figure 3

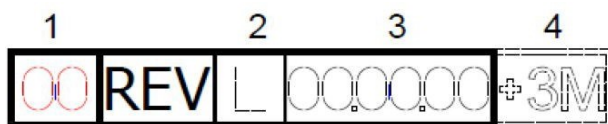

Figure 4

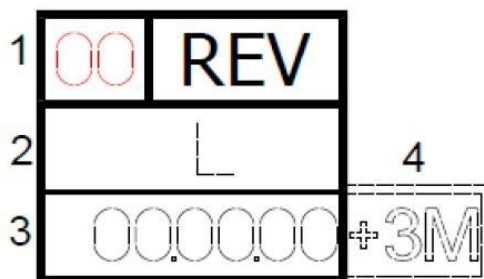
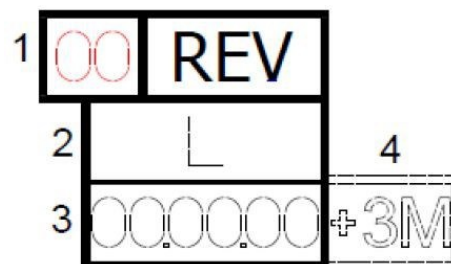

Figure 5



- 1) Maintenance plate validity period in years.
- 2) Identification mark of the workshop that carried out the maintenance work.
- 3) Date of the last overhaul (day, month, year).
- 4) Additional marking to be applied only on the instructions of the keeper.

**Position:** To the right of each solebar, or on the parts covering the solebar or on special boards fixed at the same height.

**Meaning:** From this day, plus the extended validity period of 3 months if duly indicated, the wagon formally loses its authorisation to run in normal service.



Figure 8

	<b>A</b>	<b>B<sub>1</sub></b>	<b>B<sub>2</sub></b>	<b>C<sub>2</sub></b>	<b>C<sub>3</sub></b>	<b>C<sub>4</sub></b>
<b>SS</b>	00,0	00,0	00,0	00,0	00,0	00,0

Figure 9\*

	<b>A</b>	<b>B</b>	<b>C</b>	<b>D</b>		
<b>S</b>	00,0	00,0	00,0	00,0	★ ★	★ ★ ★
<b>120</b>	00,0					

Figure 10\*

	<b>A</b>	<b>B</b>	<b>C</b>	
<b>S</b>	00,0	00,0		★ ★
<b>SS</b>	00,0			

Figure 11\*

	<b>A</b>	<b>B</b>	<b>C</b>	
<b>S</b>	00,0	00,0	00,0	★ ★

\*As an exception to this rule, the stars may also be positioned to the left of the load limit panel.

**Position:** On the left of each side wall.

- Meaning:**
- S** Maximum load in t (tonnes) for wagons running in trains operated under S conditions (maximum speed 100 km/h) with no particular operating restrictions.
  - SS** Maximum load in t (tonnes) for wagons running in trains operated under SS conditions (maximum speed 120 km/h) with no particular operating restrictions.
  - 120/00,0** Wagons only authorised to run in trains up to 120 km/h when empty (00.0 t) (figures 3 and 9).
  - Fig. 4, 5** Maximum load in t (tonnes) and maximum speed (in km/h) agreed between RUs and exceeding the load limit set out in the UIC Code.
  - ★ ★** Maximum load in t (tonnes) for wagons authorised to run in trains up to 120 km/h with a brake that does not meet all the requirements for SS conditions.
  - ★ ★ ★\*)** Maximum load in t (tonnes) for wagons authorised to run in trains up to 120 km/h with a brake that does not meet all the requirements for SS conditions. The wagons must be fitted with an automatic load-proportional braking system.

**Note 1:** Wagons should only carry the markings for line category D if, for that category of line, they can accommodate a higher maximum axle-load than for category C. Wagons should only carry the markings for line category E if, for that category of line, they can accommodate a higher maximum axle-load than for category D.

**Note 2:** For wagons carrying the “★ ★” and “★ ★ ★” signs, RUs shall define the necessary rules for the correct formation of the train (achieving the right brake percentage, timetable changes where appropriate, etc.).

\*) Marking “★ ★ ★” for all new wagons meeting the corresponding conditions entering service from 1.1.2007.

## 2.5 Sign indicating the carrying capacity

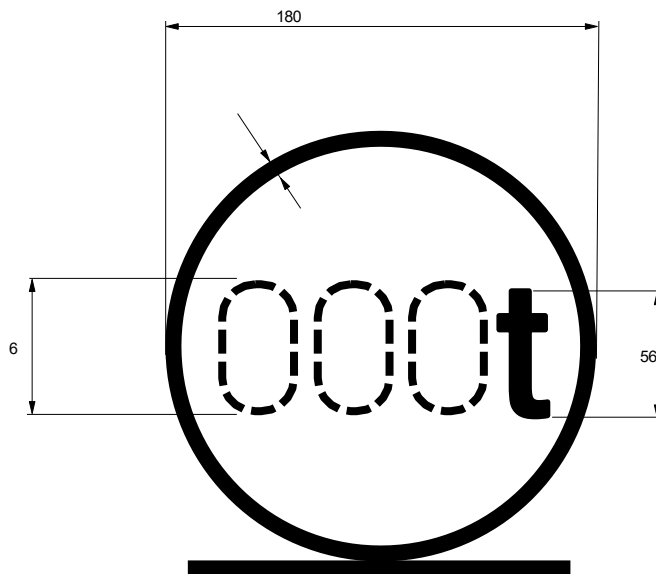

**Position:** On the right of each solebar, or on parts covering the solebar or on special boards fitted at the same height as the solebars.

**Meaning:** Sign for wagons with a carrying capacity that is greater than the maximum load marked, and for wagons with no maximum load marking [t].

**2.6 Signs indicating concentrated loads distributed over supporting surfaces of different lengths**

2.6.1 Example of concentrated loads spread over supporting surfaces of different lengths and loads resting on two separate points (width of bearing surface ≥ 2 m)

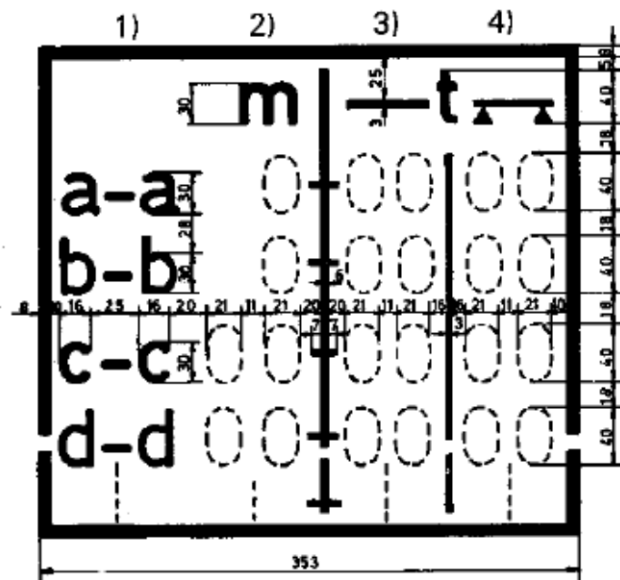
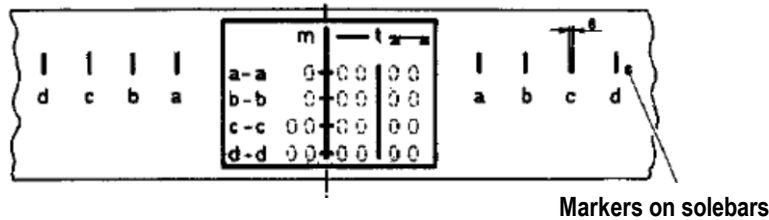

**Maximum value for different lengths:**

- of concentrated loads spread over the lengths of the supporting surface ————
- of loads resting on two supporting points ▲ —▲

- 1) Indication of the length of the supporting surfaces of the concentrated loads or distance between supporting points.
- 2) Distance, in metres, between the length markers.
- 3) Maximum value, in tonnes, of the concentrated loads.
- 4) Maximum value, in tonnes, of loads resting on two supporting points.

**Position:** In the middle of each solebar, or on parts covering the solebar or on special boards fitted at the same height as the solebars.

**Meaning:** See point 2.6.2

2.6.2 Example of concentrated loads distributed over supporting surfaces of different length and loads resting on two separate points (width of bearing surface ≥ 1.20 m)

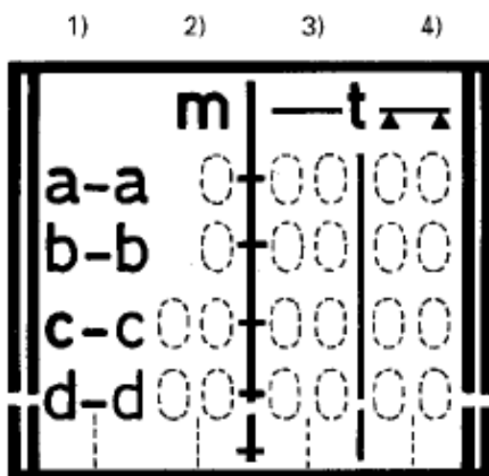
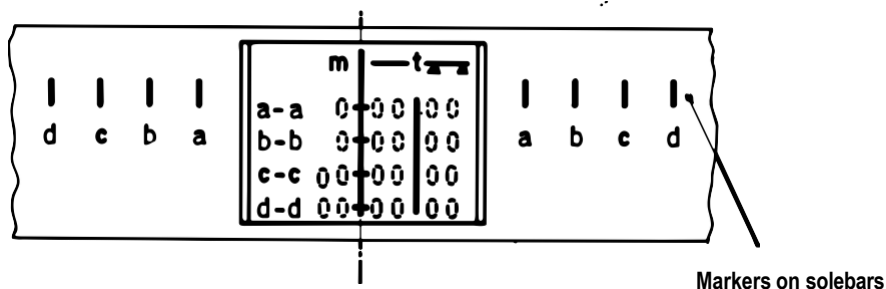

**Maximum value for different lengths:**

- of concentrated loads spread over the lengths of the supporting surface ———
- of loads resting on two supporting points ▲▲

- 1) Indication of the length of the supporting surfaces of the concentrated loads or distance between supporting points.
- 2) Distance, in metres, between the length markers.
- 3) Maximum value, in tonnes, of the concentrated loads.
- 4) Maximum value, in tonnes, of loads resting on two supporting points

**Position:** In the middle of each solebar, or on parts covering the solebar or on special boards fitted at the same height as the solebars.

**Meaning of the figures shown in points 2.6.1 and 2.6.2:** On unified flat wagons, this sign indicates the maximum values for concentrated loads and loads resting on 2 supporting points according to the stated values for the length of supporting surfaces and distances in the UIC Code. This sign is optional for other wagons which may, if required, carry the sign specified in points 2.6.1 or 2.6.2 or 2.6.3 or 2.6.4.

2.6.3 Example of concentrated loads distributed over supporting surfaces of different length  
(width of bearing surface  $\geq 2$  m)

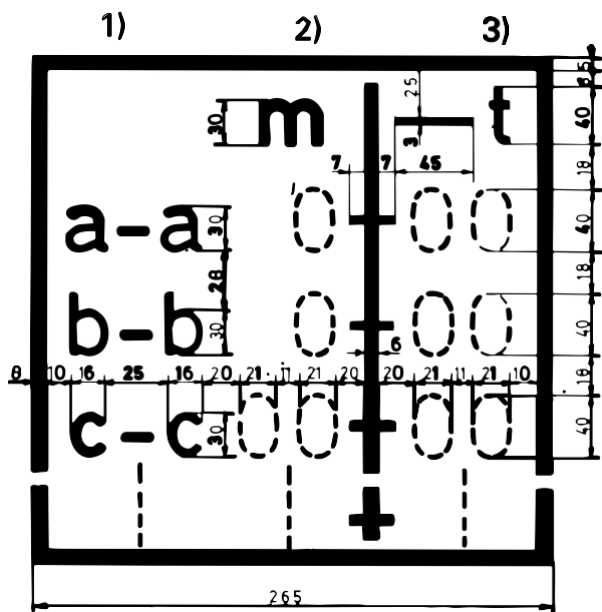
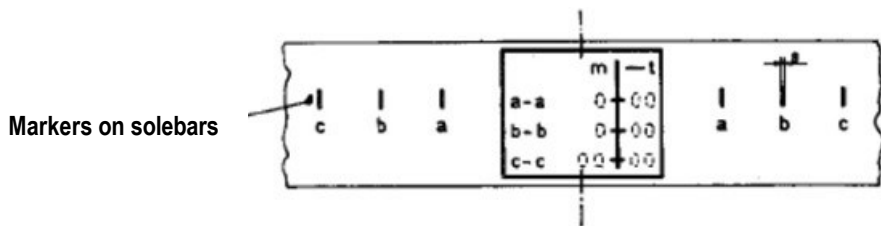

**Maximum value for different lengths:**  
 - of concentrated loads spread over the lengths of the supporting surface ———

- 1) Indication of the length of the supporting surfaces of the concentrated loads or distance between supporting points.
- 2) Distance, in metres, between the length markers.
- 3) Maximum value, in tonnes, of the concentrated loads.

**Position:** In the middle of each solebar, or on parts covering the solebar or on special boards fitted at the same height as the solebars.

**Meaning:** See point 2.6.4.

2.6.4 Example of concentrated loads distributed over supporting surfaces of different length (width of bearing surface  $\geq 1.20$  m)

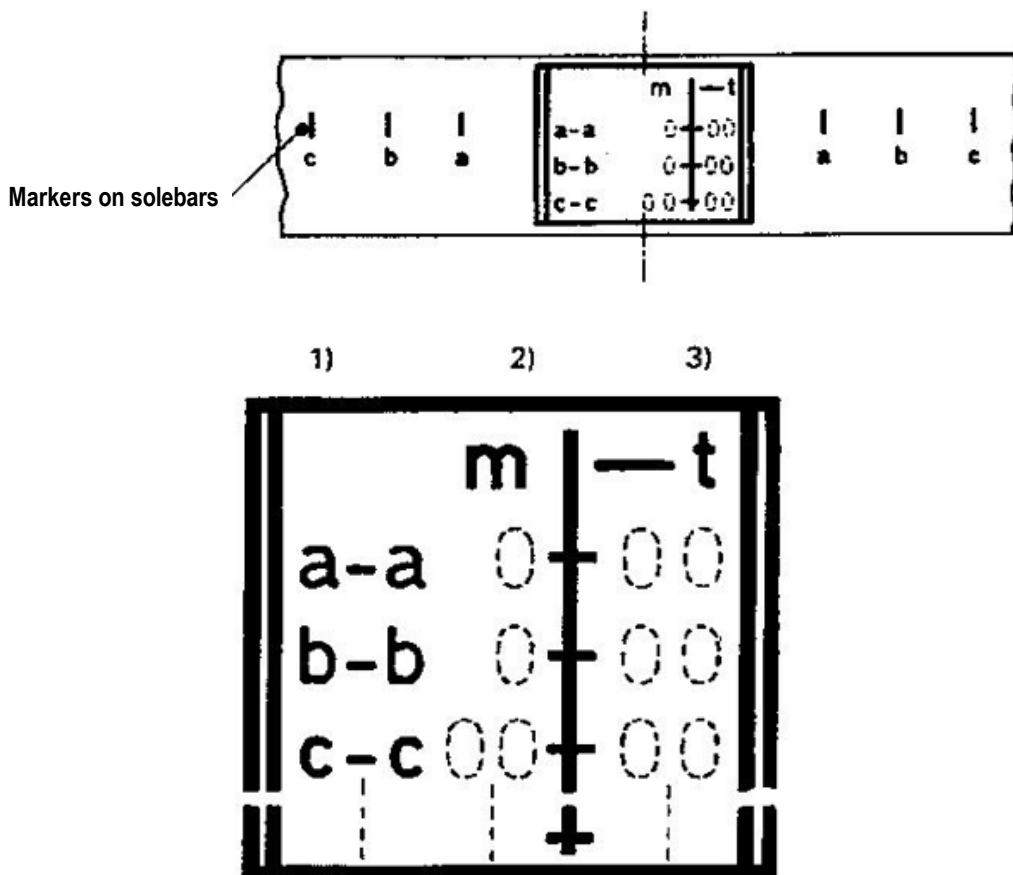

**Maximum value for different lengths:**

- of concentrated loads spread over the lengths of the supporting surface ———

- 1) Indication of the length of the supporting surfaces of the concentrated loads or distance between supporting points.
- 2) Distance, in metres, between the length markers.
- 3) Maximum value, in tonnes, of the concentrated loads.

**Position:** In the middle of each solebar, or on parts covering the solebar or on special boards fitted at the same height as the solebars.

**Meaning of the figures shown in points 2.6.3 and 2.6.4:** For flat wagons not covered by points 2.6.1 and 2.6.2, with a loading plane more than 10 m long, and high-sided open wagons built after 1 January 1968, this sign indicates the maximum value for concentrated loads spread over supporting surfaces for at least three different lengths. This sign is optional for other wagons.



**2.7 Signs indicating the volumetric capacity of wagons and the type of goods permitted for transport**

Figure 1: Tank and cask wagons

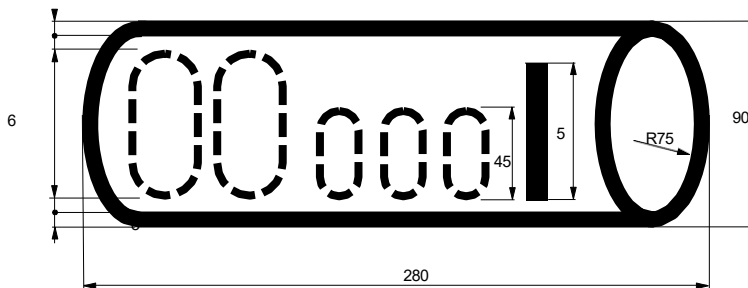

**Position:** On the left of each side wall (for tank and cask wagons, on the tank itself or on special boards).

**Meaning:** Capacity in l

For tank wagons, this sign should also specify the commodities that the vehicle is authorised to carry, if required by the RID for the carriage of dangerous goods.

Figure 2: Hopper and box wagons

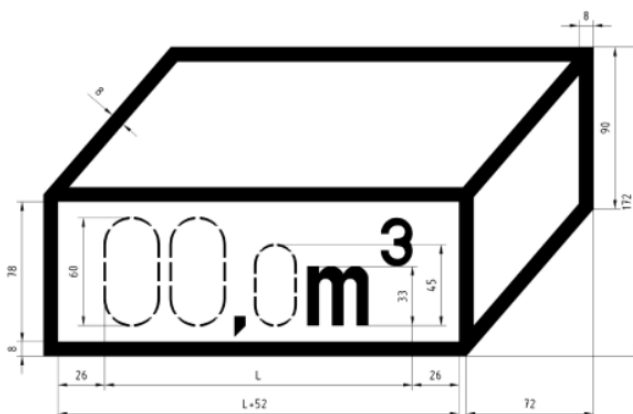

**Position:** On the left of each side wall (for hopper and box wagons, on the tank itself or on special boards).

**Meaning:** Capacity in m<sup>3</sup> according to the type of wagon.

**Note:** If 99.9 m<sup>3</sup> are exceeded, add an additional first digit.

## 2.8 Signs indicating the length of load and floor space

Figure 1: Length of load

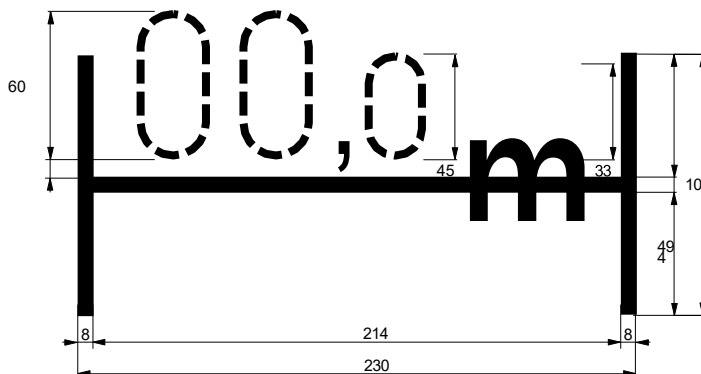

**Position:** On the left of each side wall.

**Meaning:** Loading length in [m] for flat wagons and covered wagons with a flat floor, minus the thickness of any intermediate partitions (useful length).

Figure 2: Floor space

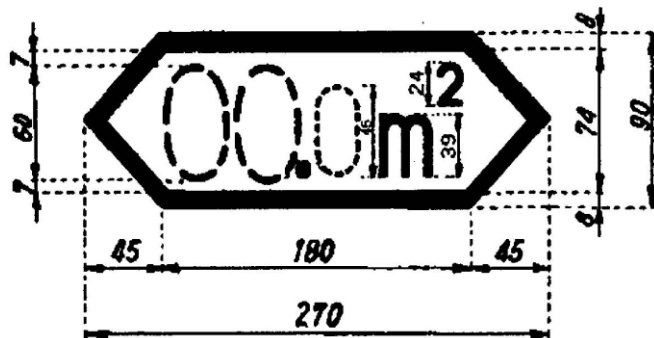

**Position:** On the left of each side wall.

**Meaning:** Surface area [m<sup>2</sup>] of the floor of covered wagons and wagons with an opening roof and flat floor.

**2.9 Sign indicating the distance between end axles and bogie centres**



**Position:** On the right of each solebar, or on the bogie frame (it is sufficient for the sign to feature on the left-hand side of the bogie, on each side of the wagon) or on parts covering the solebar or on special boards fitted at the same height as the solebars.

**Meaning:** Indicates the distance:  
 – between the end axles of bogies and of wagons other than bogie wagons,  
 – between the bogie centres of bogie wagons.

**2.10 Sign indicating spark arrestor plates**

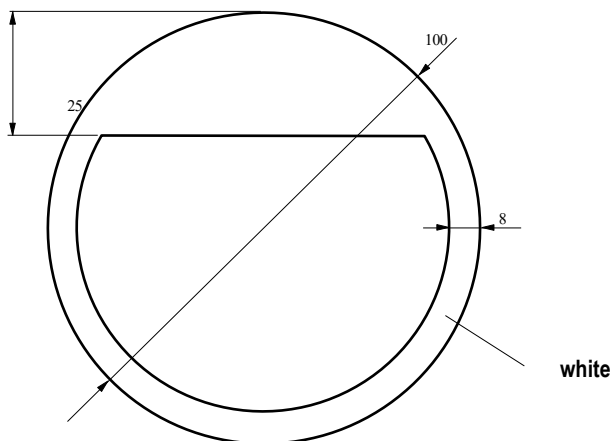

**Position:** In the middle of each solebar, or on parts covering the solebar or on special boards fitted at the same height as the solebars. This sign may also be affixed on the right of each side wall.

**Meaning:** Wagon fitted with spark-arrestor plates in accordance with Appendix A to **UIC leaflet 543**; these plates are required for axle wagons suitable for carrying class 1 commodities, sub-classes 1.1, 1.2, 1.3, 1.5 and 1.6, as well as certain commodities in classes 4.1 and 5.1 (RID, Part 7, points 7.2.4 and W 8).

**2.11 Additional signs for wagons accepted for running in Great Britain**

(NETWORK RAIL infrastructure except HS 1 high-speed line from Dollands Moor to London St Pancras International) for wagons accepted on ferries or authorised to use the Cross-Channel Fixed Link (CCFL)

Figure 1: For wagons accepted on ferries and authorised to run in Great Britain (NETWORK RAIL infrastructure)

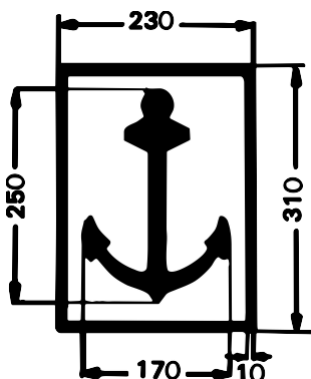
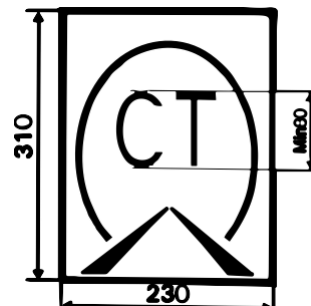

Figure 2: For wagons authorised to use the Cross-Channel Fixed Link (CCFL) and run in Great Britain (NETWORK RAIL infrastructure)



Figures 3a, 3b, 3c: For wagons accepted on ferries and authorised to use the Cross-Channel Fixed Link (CCFL) and run in Great Britain (NETWORK RAIL infrastructure)

Figure 3a

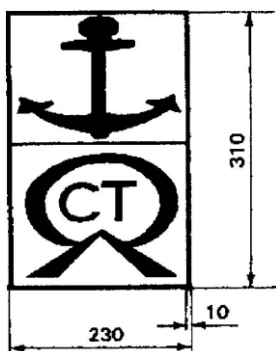

Figure 3b

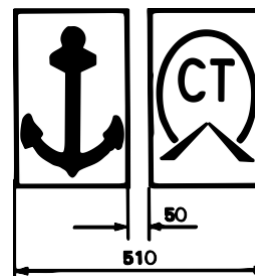
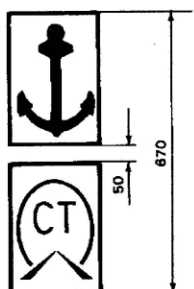

Figure 3c



**Position:** On the left of each side wall.

**Meaning:** These signs are only to be used on wagons that are authorised to run on the British rail network, based on either Figure 1 or Figure 2, or a combination of both (Figures 3a, 3b or 3c).

**Note:** Neither of these signs is necessary to use the Cross-Channel Fixed Link (Frethun to Dollands Moor) or the HS 1 high speed line from Dollands Moor to London St Pancras International.

## 2.12 Sign for ferry ramp angle

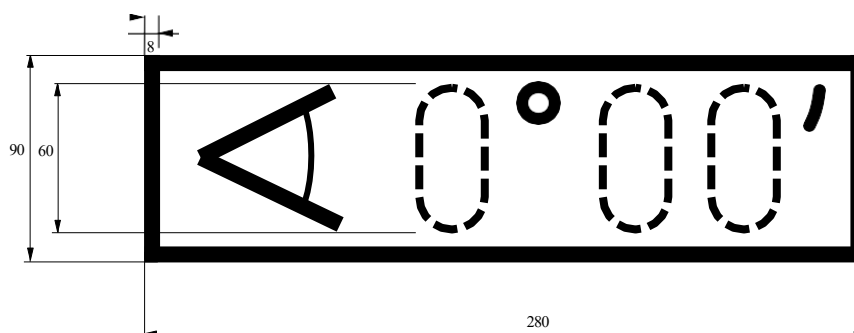

**Position:** On the left of each solebar, or on parts covering the solebar or on special boards fitted at the same height as the solebars.

**Meaning:** Indicates bogie wagons that can only negotiate a ramp angle of less than  $2^{\circ}30'$  when running onto ferries.

This sign must be carried by bogie wagons which, when entering a ferry, can only negotiate a ramp angle of less than  $2^{\circ}30'$ . The marking should specify the maximum ramp angle.

**Note:** Regulations governing wagons that run on ferries are contained in GCU **Appendix 14**.

**2.13 Sign for removable wagon accessories**

Removable wagon accessories

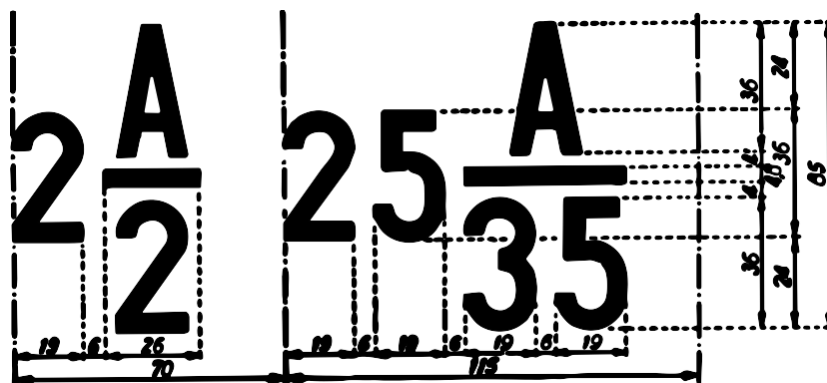

**Position:** On the right of each side wall.

**Meaning:** The number and type of removable accessories are to be indicated. In the case of carboy wagons and wagons with removable recipients, the number of such recipients should be indicated. The figure placed before the fraction indicates the number of removable accessories belonging to the wagon; the letter "A" indicates that the accessories are removable, and the denominator of the fraction gives the serial number assigned to the removable accessory in the list below. The names of the accessories may also be added in letters alongside these signs.

Serial number	Description of the removable accessory
1	Removable stanchion
2	Removable side board for flat wagon
3	Removable end board for flat wagon
4	Removable side panel
5	Removable centre post for securing load
6	Stanchion chain
7	Crank handle for car-carrying wagons
8	Adjustment device
9	Swivelling bolster with stanchions
10	Removable bolster
11 – 12	– reserved –
13	– reserved –
14	– reserved –
15 – 16	– reserved –
17	– reserved –
18	– reserved –
19	– reserved –

20	– reserved –
21	– reserved –
22	– reserved –
23	– reserved –
24	Coupling rod (rigid coupling)
25	– reserved –
26	Ice tank or bunker
27	Ice tank screen
28	Ice tank frame
29	Trestle or bar with meat hooks
30	Removable cross-piece for low-loader wagons
31	Removable support bracket (for wagons used for special loads)
32	Securing crossbar (for wagons used for special loads)
33	Removable floor panel (for wagons used for special loads)
34	– reserved –
35	Wedging block
36	Skid, with or without shoes, flat wagons used for carrying cars
37	Securing belts for flat wagons used for carrying cars
38	Girder for removable ramps for flat wagons used for carrying cars
39	– reserved –
40	Spare heating coupling
41	Fire extinguishers
42	Wheel scotches for car-carrying vehicles
43	Loading ramp, gangway
44	– reserved –
45	– reserved –
46	– reserved –
47	Metal cradles for rolls of sheeting
48	Panel for covering markings
49	Loading frame for special types of goods

## 2.14 Sign for the inside of wagons: "Do not use nails or wire staples"

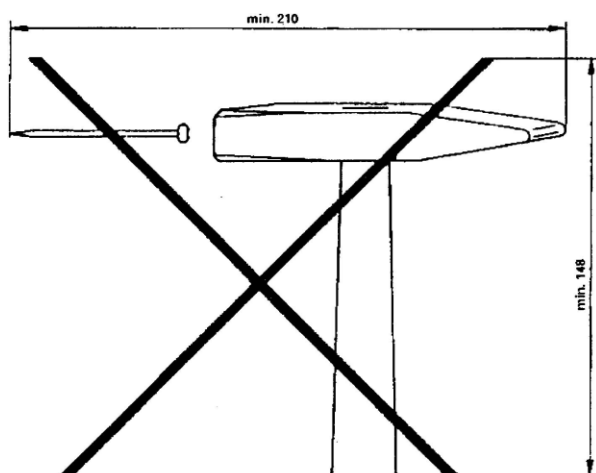

**Hammer and nail: Outline in black**  
**Cross: Black or red**

**Position:** Inside the wagon in a clearly visible place, if possible, at eye level.

**Meaning:** Nails or staples should not be used on the walls or floor of this wagon.

## 2.15 Markings for wagons with special fittings (wagons with automatic discharge facility, opening roof, etc.)

Example:	<p><i>Wandarretierung lösen durch Schließen und Öffnen mit Bedienhebel.</i></p> <p><b>Release wall locking device by closing and opening with control lever.</b></p>	<p><i>Débloquer l'arrêt mural en l'ouvrant et le fermant avec le levier de commande.</i></p> <p><i>Allentare il blocco della parete mediante chiusura e apertura con la leva di servizio.</i></p>
----------	--	---

**Position:** At suitable places on both sides of the wagon.

**Meaning:** Instructions on how to operate these fittings and the safety measures to be taken, if possible, in several languages.  
 Suitable pictograms can be added to these instructions.



## 2.16 Signs for wagons built for running between countries with different track gauges

Signs for wagons built for running between countries with different track gauges:

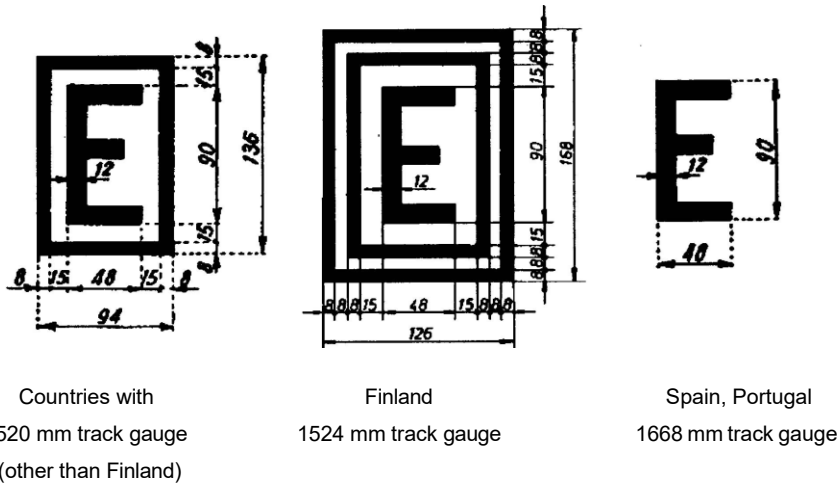

**Position and meaning:** see point 2.17

## 2.17 Signs for bogies with gauge-adjustable axles, nominal gauge 1435 mm (automatic gauge changeover facility according to the UIC leaflet 510-4)

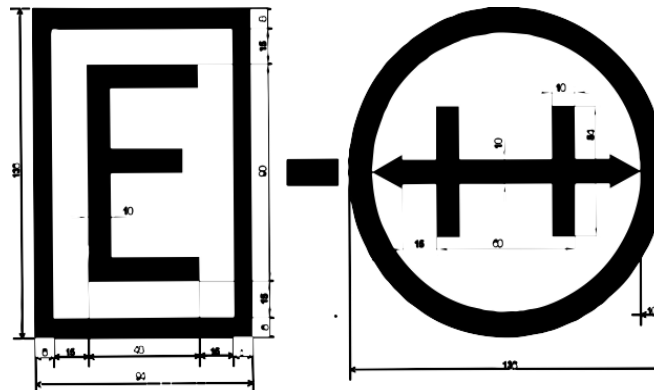

**Position:** On the right of each side wall. The right-hand sign on its own also features on the bogie frame.

**Meaning:** The signs shown in point 2.16, which indicate compliance with **UIC leaflets 430- 1** or **430-3**, are affixed to wagons suitable for running between countries with different track gauges. For wagons fitted with automatic gauge changeover facilities, the sign in 2.16 is placed alongside that in point 2.17.

**Note 1:** When changing axles of this type, the date (month and year) of the last axle-box overhaul must be marked, along with the code number of the wagon keeper (owning RU or RU with which the keeper has concluded a service agreement) on the outside of each axle-box in white paint, clearly visible. Exchangeable bogies are to be fitted with a special overhaul plate.

**Note 2:** Regulations concerning the use of wagons with interchangeable axles in traffic across the Pyrenees and in traffic with Finland are given in GCU **Appendix 14**.

## 2.18 Sign for bogies fitted with gauge-adjustable axles, nominal gauge 1520 mm (automatic gauge changeover facility according to the UIC leaflet 510-4)

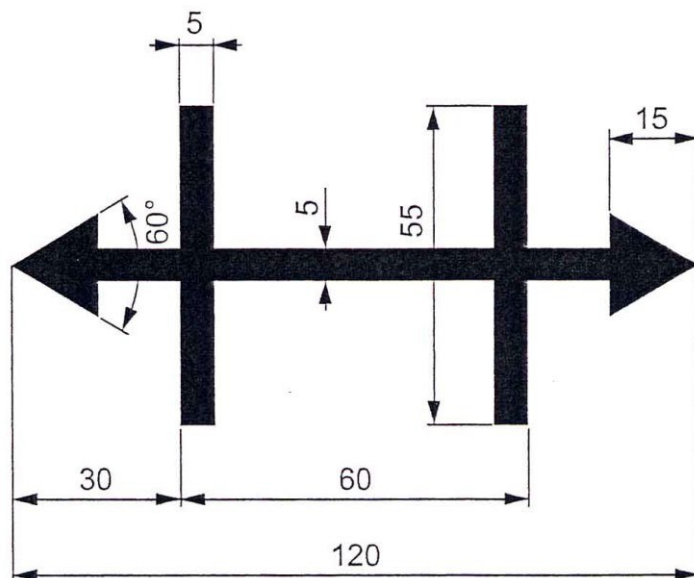

**Position:** On the corresponding bogie frames.

**Meaning:** This sign is used by RUs that are signatories to the PPW\*.

The provisions of point 2.17 apply in principle.

This sign is carried by wagons that have bogies fitted with gauge-adjustable axles with a nominal gauge of 1520 mm. Wagons fitted with bogies of this type should carry the appropriate combination of the signs shown in points 2.16 and 2.18 on the right of each side wall.

\*PPW Agreement among members of the OSJD\*\*:  
"Regulations governing the use of wagons in international traffic"

\*\*OSJD Organisation for Collaboration between Railways, based in Warsaw

### 2.19 Additional signs for wagons accepted for running in Spain and Portugal

Figure 1: For wagons fitted with a vacuum brake

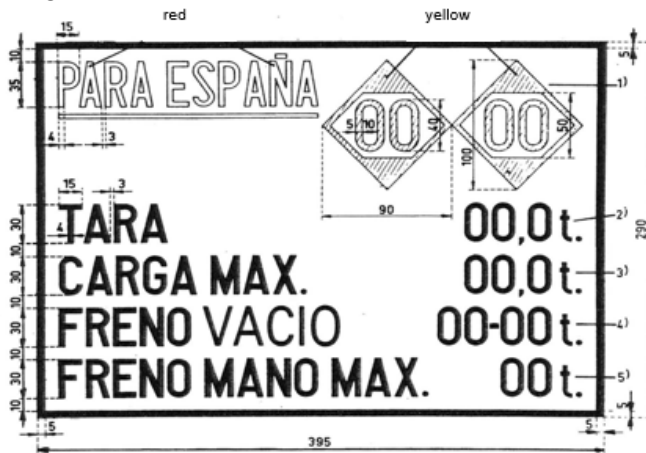

**Position:** On the right of each side wall, in black on wagons that are painted white, and in white on a blue background for other wagons.

- Meaning:**
- |                      |  |
|----------------------|--|
| 1. Left-hand diamond | Maximum speed at maximum load  |
| Right-hand diamond   | Maximum speed when empty. When the maximum speeds when empty and at maximum load are the same, a single diamond marking will suffice |
| 2. TARA              | Vehicle tare   |
| 3. CARGA MAX         | Maximum load limit   |
| 4. FRENO VACIO       | Vacuum brake   |
|                      | Left-hand figure= braked weight in "empty" position  |
|                      | Right-hand figure= braked weight in "loaded" position  |
| 5. FRENO MANO MAX    | Maximum braked weight of the screw brake   |

Figure 2: For wagons with only one brake pipe for the vacuum brake:

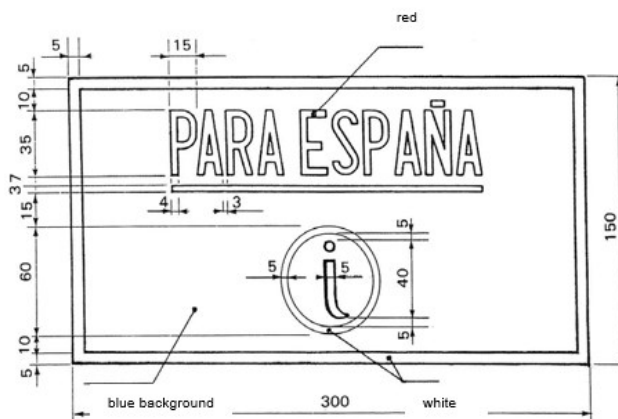

**Position:** On the right of each side wall, in black on wagons painted white and in white on a blue background for other wagons.

**Meaning:** Wagon can be included in a train with the brake isolated.

### 2.20 Approval plate for vehicles without the TEN marking

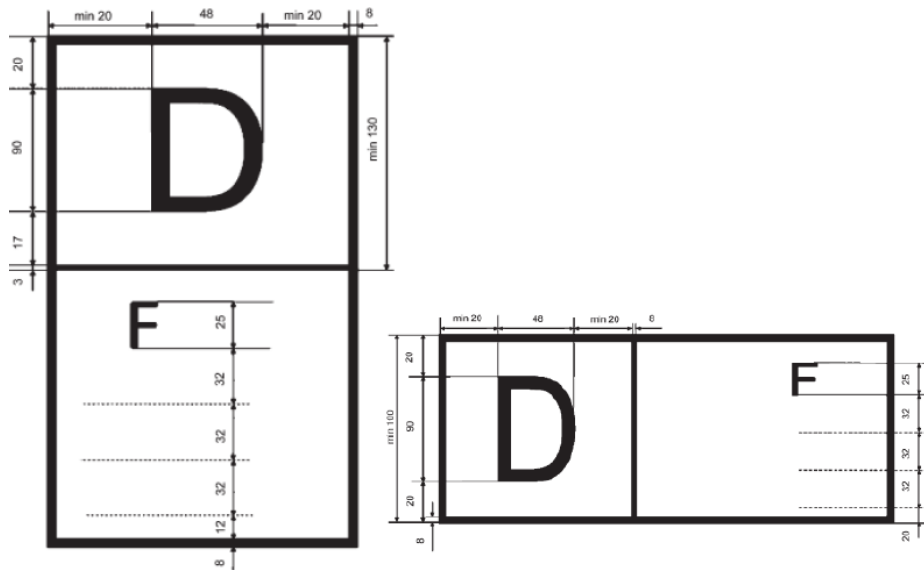

Vehicles which are not authorised for operations in all member states require an indication of the member state in which they are authorised. The list of authorising member states is to be indicated in accordance with one of the following drawings, where “D” stands for the member state which first issued authorisation (here: Germany), and “F” for the second member state which issued authorisation (here: France).

The member states are to be indicated using the codes in Annex P.4. This may concern both TSI-compliant and non-TSI-compliant vehicles. The first digit in these vehicles’ codes as per Annex P.6 is code 4 or 8.

### 2.21 Marking of wagon gauge

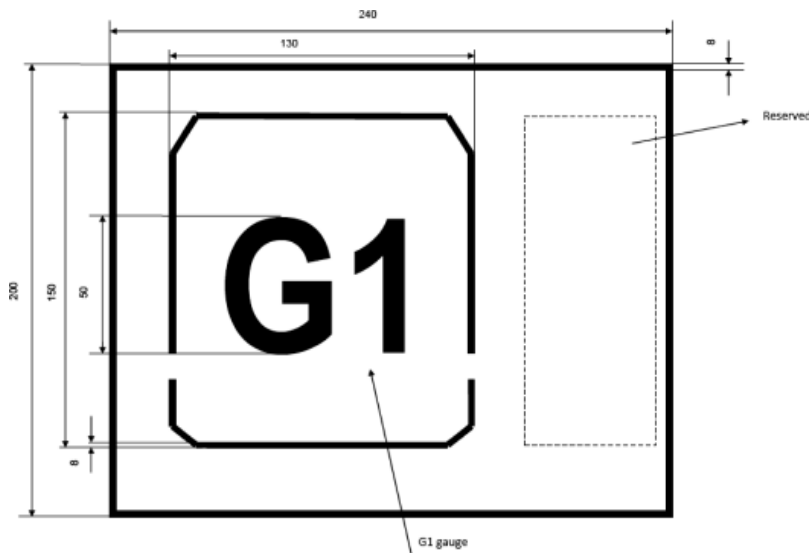

Indicates wagons built to gauge “G1” and authorised for interoperable traffic.

### 3.1 Height of the loading plane for container wagons in unladen state

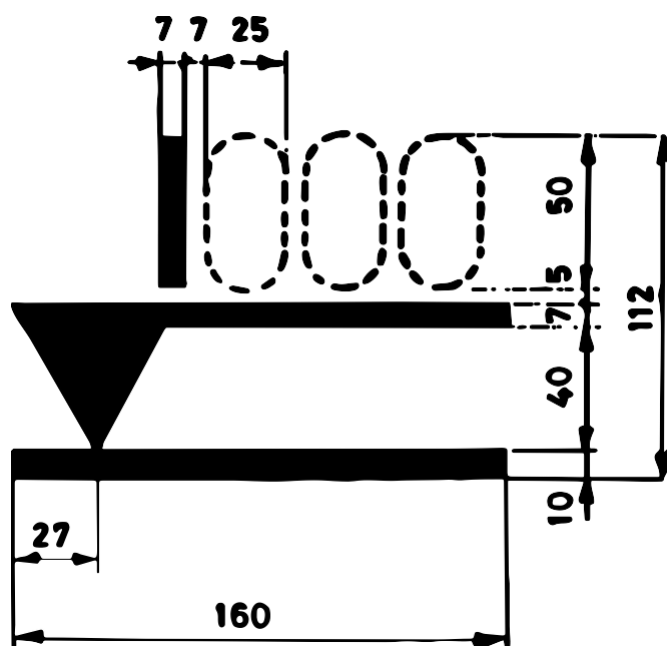

**Position:** On the right of each solebar.

**Meaning:** This sign is carried by container wagons that are suitable for transporting large containers and/or swap bodies. It indicates the height in millimetres of the loading plane when the wagon is not loaded.

### 3.2 Signs for combined transport wagons in accordance with IRS 50596-6

On swap-body carrier wagons and on carrier wagons with independent axles that have equivalent or more favourable characteristics for the coding of load units.

ISO containers on carrier wagons with a bogie pivot pitch > 16.15 up to and including 19.30 m

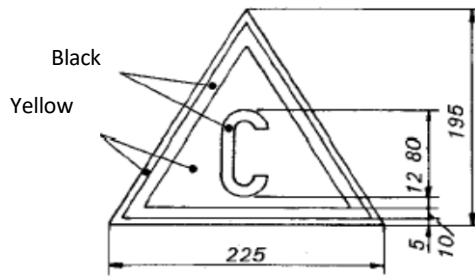

On type 1a and 1b recess wagons or variants for carrying semi-trailers that exceed specified capacity

On recess wagons for semi-trailers

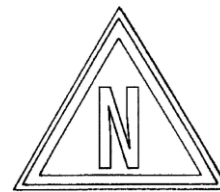
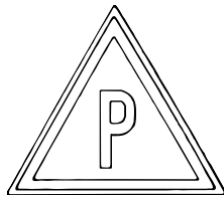



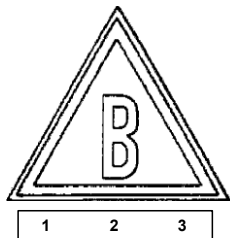



On roller-unit carrier wagons



**Position:** On the left of each side wall.

For wagons used in rail/road combined transport, the following signs:

- On recess wagons for semi-trailers whose characteristics are defined in **IRS 50596-6**
- On recess wagons for semi-trailers whose characteristics are defined in **IRS 50596-6**
- On swap-body carrier wagons whose characteristics are defined in **IRS 50596-6**
- On roller-unit carrier wagons whose characteristics are defined in **IRS 50596-6**

- |   |   |   |  |
|---|---|---|--|
| - |  |   |  |
|   |   | On swap-body carrier wagons whose characteristics do not meet the conditions of point 3.2.3 of <b>IRS 50596-6</b> |  |
- |  |   |  |  |
|--|---|--|--|
|  |  |  |  |
|  | +23   | On swap-body carrier wagons whose characteristics are more favourable than the conditions in point 3.2.3 of <b>IRS 50596-6</b> |  |
- |   |   |   |  |
|---|---|---|--|
| - |  |   |  |
|   |   | On carrying wagons for ISO containers whose characteristics do not meet the requirements of point 3.2.3 of <b>IRS 50596-6</b> |  |
- |   |   |  |  |
|---|---|--|--|
| - |  |  |  |
|   |   | On recess wagons whose characteristics when carrying semi-trailers do not meet the conditions of point 3.2.3 of <b>IRS 50596-6</b> |  |
- |   |   |   |  |
|---|---|---|--|
| - |  |   |  |
|   | +5  | On recess wagons whose characteristics when carrying semi-trailers are more favourable than the conditions in point 3.2.3 of <b>IRS 50596-6</b> |  |
- |   |   |   |  |
|---|---|---|--|
| - |  |   |  |
|   | 1 2 3   | On roller-unit carrier wagons whose characteristics do not meet the conditions of point 3.2.3 of <b>IRS 50596-6</b> |  |
|   | +3  |   |  |
|   | -2  |   |  |
- |   |   |  |  |
|---|---|--|--|
| - |  |  |  |
|   | 1 2 3   | On roller-unit carrier wagons whose characteristics are more favourable than the conditions in point 3.2.3 of <b>IRS 50596-6</b> |  |
|   | +6  |  |  |

Pictogram for seating devices unsuitable for use with steering wedges

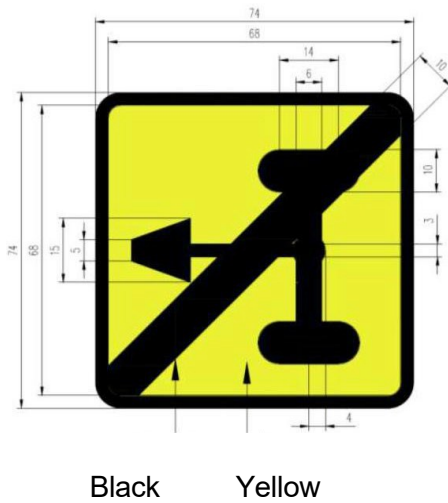

If the seating device is unsuitable for use with steering wedges, the recess wagon is to be marked with the following pictogram, near the wagon compatibility code.

Pictogram to affix for heavy-duty swap bodies transport

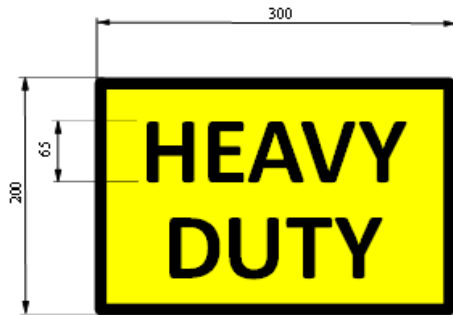

This pictogram is positioned on the solebar near the compatibility code of the wagon on the carrier wagon **with marking of reinforced tensioning fittings**



Loading diagram for carrier wagons for heavy-duty swap bodies transport

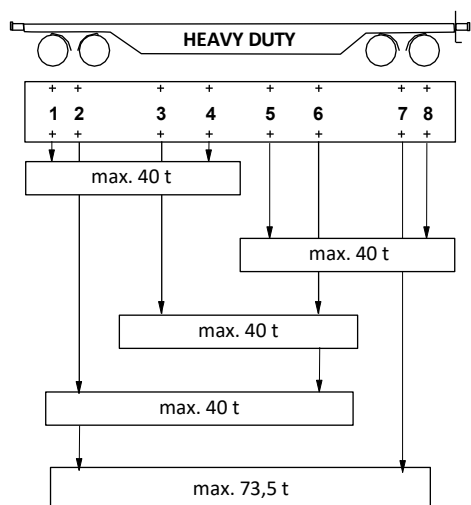

The loading diagram must be affixed to wagons with reinforced tensioning fittings.  
 The inscription shall indicate the maximum total permissible mass for each loading position.  
 The loading diagram shall be at least A4 size and shall be affixed to the solebar.

**On swap-body carrier wagons whose characteristics do not meet the conditions of point 3.2.3 of IRS 50596-6**

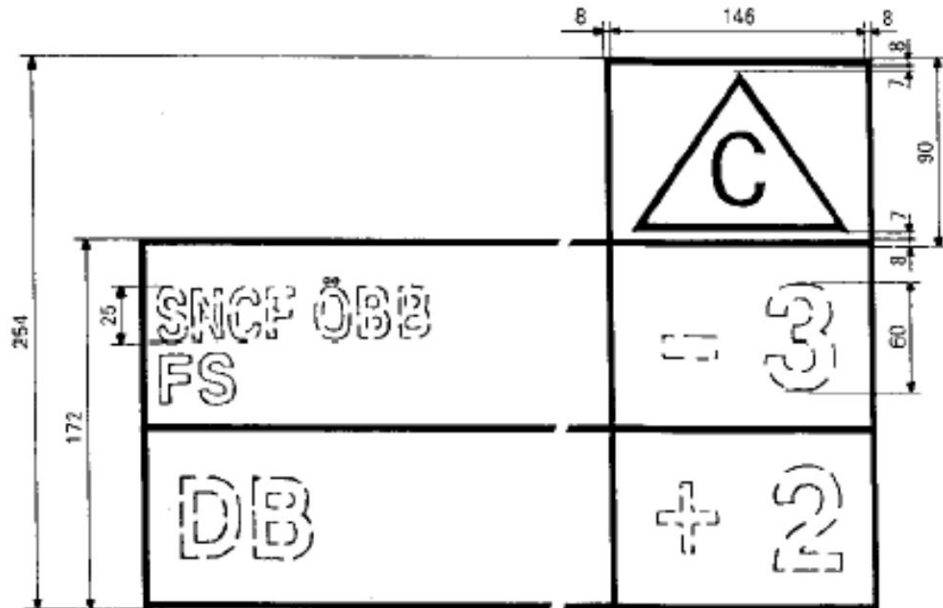

On swap-body carrier wagons with characteristics more favourable than the conditions in point 3.2.3 of IRS 50596-6

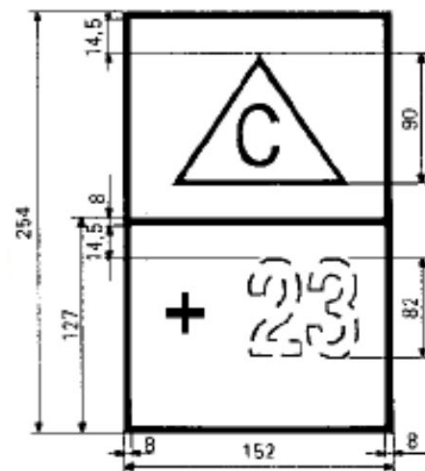

**Meaning:**

- 3: The wagon can only be loaded with swap bodies that have a profile number that is lower (in this example by at least 3 points) than the profile number assigned to the RU (or RUs) concerned.
- + 2: The wagon can be loaded with swap bodies that have a profile number that is greater (in this example by up to 2 points) than the profile number assigned to the RU (or RUs) concerned.
- + 23: The wagon can be loaded with swap bodies that have a profile number that is greater (in this example by up to 23 points) than the profile number assigned to the RU (or RUs) concerned.

**On recess wagons whose characteristics when carrying semi-trailers do not meet the conditions of point 3.2.3 of IRS 50596-6**

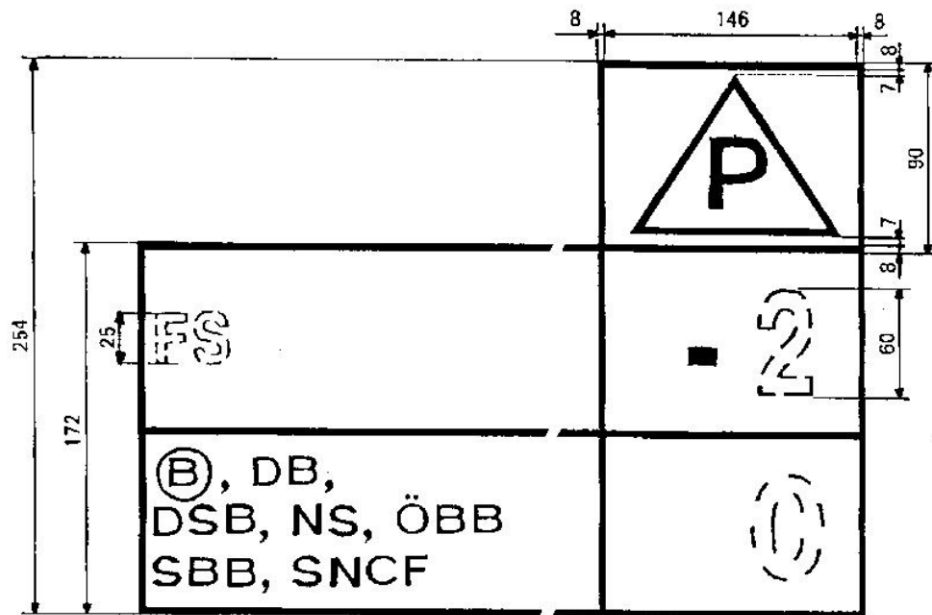

On recess wagons whose characteristics when carrying semi-trailers are more favourable than the conditions in point 3.2.3 of IRS 50596-6

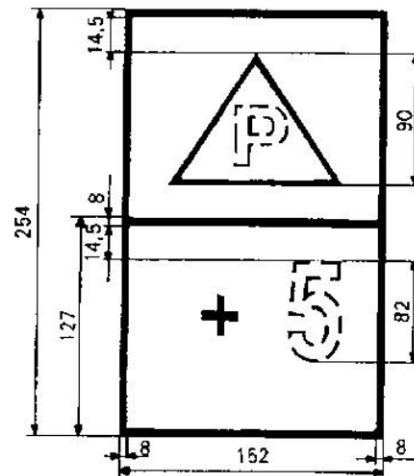

**Meaning:**

- 2: The wagon may only be loaded with semi-trailers that have a profile number that is lower (in this example by at least 2 points) than the profile number assigned to the RU (or RUs) concerned.
- 0: The wagon may only be loaded with semi-trailers that have a profile number that is no higher than the profile number assigned to the RU (or RUs) concerned.
- +5: The wagon can be loaded with semi-trailers that have a profile number that is greater (in this example by up to 5 points) than the profile number assigned to the RU (or RUs) concerned.

**On roller-unit carrier wagons whose characteristics do not meet the conditions of point 3.2.3 of IRS 50596-6**

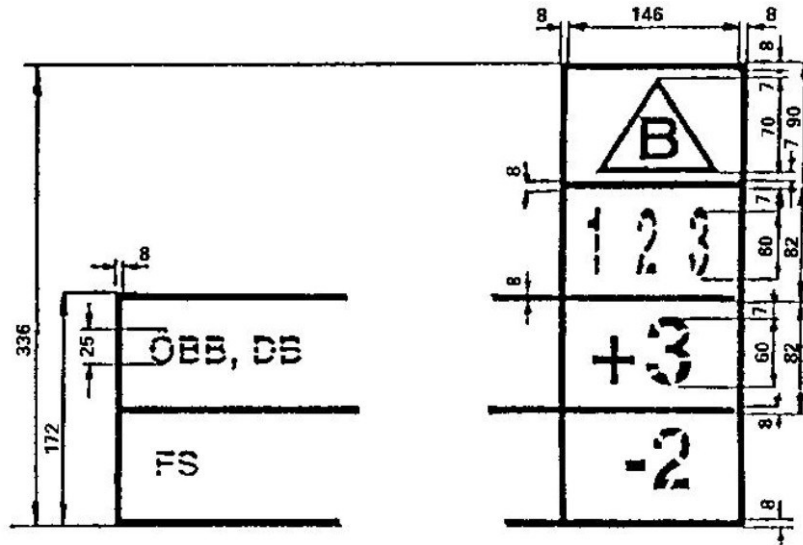

On roller-unit carrier wagons with characteristics more favourable than the conditions in point 3.2.3 of IRS 50596-6

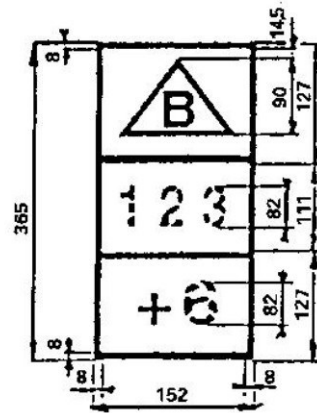

**Meaning:**

- +3: The wagon may be loaded with roller units that have a profile number that is greater (in this case by up to 3 points) than the profile number assigned to the RU (or RUs) concerned.
- 2: The wagon may only be loaded with roller units that have a profile number that is lower (in this example by at least 2 points) than the profile number assigned to the RU (or RUs) concerned.
- +6: The wagon may be loaded with roller units that have a profile number that is greater (in this example by up to 6 points) than the profile number assigned to the RU (or RUs) concerned.

**Compatibility code definition in accordance with IRS 50596-5**

Recess wagons with enlarged clearance envelopes are given a compatibility code which takes the form of the code letter from the wagon compatibility code (in this case "P") and one of the lower-case letters approved by UIC for specific clearance envelopes/wagon types.

The letters are marked on the recess wagon and in the semi-trailer code number plate and must match when loaded.



Clearance envelope for P semi-trailers with compatibility code "a" on type 4 recess wagon with seating device 113 or 98 cm high

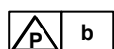

Clearance envelope for P semi-trailers with compatibility code "b" on recess wagon, types BA 739 and 744 with seating device 113 or 98 cm high



Clearance envelope for P semi-trailers with compatibility code "c" on type 2000 recess wagon with seating device 113 or 98 cm high



Clearance envelope for P semi-trailers with compatibility code "d" on Mega 2 type recess wagon with seating device 113, 98 or 85 cm high



Clearance envelope for P semi-trailers with compatibility code "e" on type 5 recess wagon with seating device 113, 98 or 88 cm high



Clearance envelope for P semi-trailers with compatibility code "f" on type 3000 recess wagon with seating device 113, 98 or 88 cm high



Clearance envelope for P semi-trailers with compatibility code "g" on Twin type recess wagon with seating device 113, 98 or 88 cm high



Clearance envelope for P semi-trailers with compatibility code "h" on type 4.2 recess wagon with seating device 113 or 98 cm high



Clearance envelope for P semi-trailers with compatibility code "i" on type MTW recess wagon with seating device 113, 98 or 88 cm high

#### 4.1 Sign for length over buffers

Length over buffers



**Position:** On the left of each side wall.

**Meaning:** Indicates the wagon's length over buffers in metres [m].

On wagons made up of separate units joined together by a permanent coupling (multiple wagon units) the total length of the wagon should be indicated.

### 4.2 Signs for tare and braked weight

Figure 1: Wagon tare



Figure 2: Wagon tare and braked weight of the platform-operated hand brake

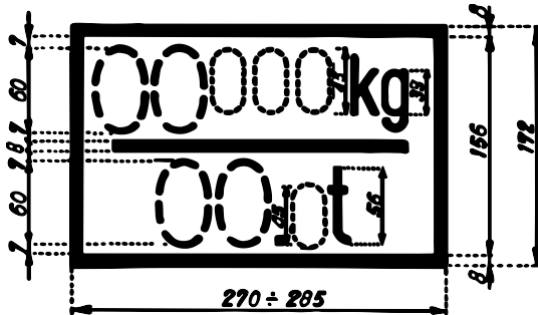
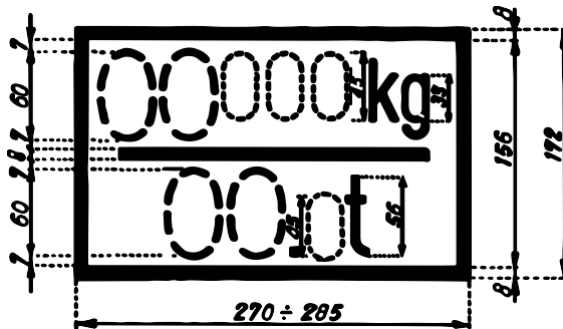

Figure 3: Wagon tare and braked weight of the ground-operated hand brake (the latter to be shown in a red box)



**Position:** On the left of each side wall

**Meaning:** Indicates the wagon tare (upper figure) and braked weight (lower figure).  
 The sign shown in figures 2 or 3 is marked on the wagon when the braked weight is less than the total mass of the vehicle (tare + load corresponding to the maximum weight).  
 The braked weight as shown in figure 3 must be marked in a red box when it refers to a ground-operated hand brake.  
 When a wagon is fitted with more than one independently acting hand brake, the corresponding number of brakes must be indicated in front of the braked weight marking (for example: 2 x 00.0 t).

**Note:** The sign shown in Figure 1 must **not** be affixed to a wagon that is to carry the sign in Figure 2 or 3.

Figure 4: Marking indicating the braked weight and the holding force in kN on vehicles fitted with screw brakes

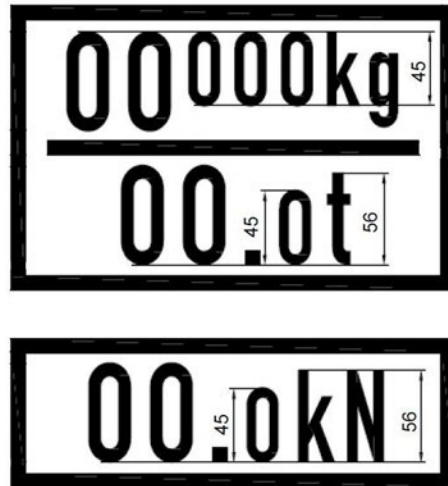

**Note:** If the wagons are equipped with more than one screw brakes independent of each other, it is appropriate to specify the quantity in front of the relevant indication of holding force (e.g. 2 x 00.0 kN)

This marking is mandatory as of 1/1/2021.



### 4.3 Signs to indicate the changeover device for air brakes - Marking of the braked weight on wagons.

#### 4.3.1 Marking of the braked weight of wagons without changeover device

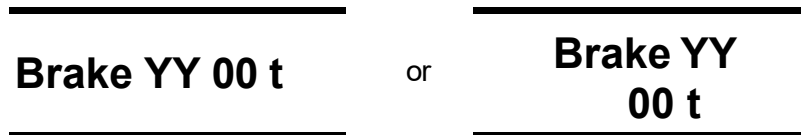

**Position:** On each solebar, close to the indication of the brake system.

**Meaning:** Sign indicating the brake type (YY) as shown in point 4.3.9 and indication of the braked weight (t). This marking may be preceded by the word "brake" (optional).

#### 4.3.2 "Goods — Passengers" (G/P) changeover device (hand operated)

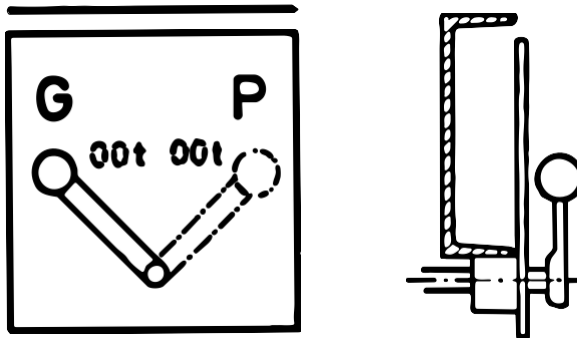

**Position:** On the plate behind the changeover lever, alongside the corresponding lever position, if the braked weights (t) in the "Goods" (G) and "Passengers" (P) positions are different.

**Meaning:** On wagons that are fitted with a "goods — passengers" (G/P) changeover device, the changeover from one regime to another is made using a lever fitted with an end knob (as illustrated in point 4.3.2).

In the "goods" braking mode, the lever slants upwards and to the left.

In the "passengers" braking mode, the lever slants upwards and to the right.

4.3.3 "Empty – loaded" changeover device (hand operated)

Vehicles fitted with a single "empty – loaded" changeover device (figures 1 and 2)

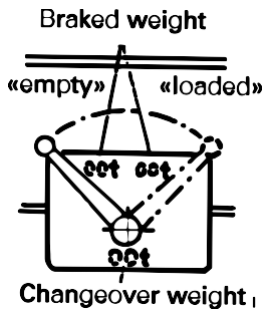

**Fig. 1:**  
«Empty»  
braking position  
plus one «Loaded»  
braking position

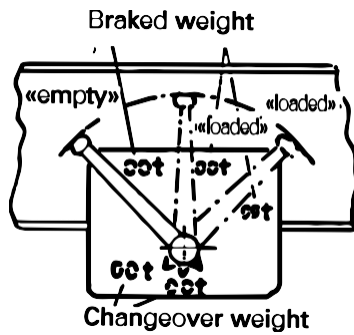
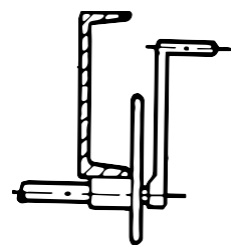

**Fig. 2:**  
«Empty» braking  
position plus several  
(for example two)  
«Loaded» braking  
positions

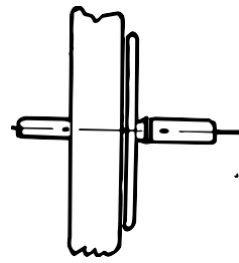

Vehicles fitted with 2 or more "empty – loaded" changeover devices (figures 3 and 4)

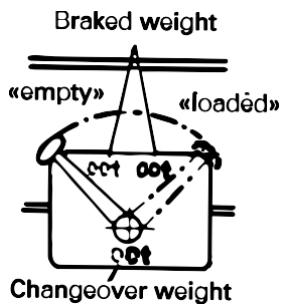

**Fig. 3:**  
«Empty» braking  
position plus one  
«Loaded» braking  
position

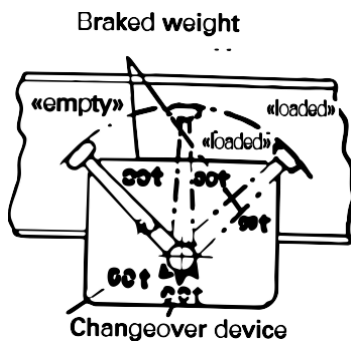
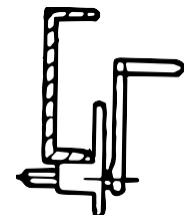

**Fig. 4:**  
«Empty» braking  
position plus several  
(for example two)  
«Loaded» braking  
positions

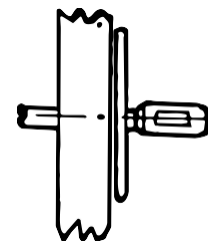

**Position  
(figures  
1 to 4):**

On each solebar, approximately in the middle of the wagon, on the plate behind the changeover lever. The braked weights (t) are marked next to the corresponding position of the lever. The changeover weights [t] are indicated on the same plate, near the point of rotation of the lever.

**Meaning:**

On wagons featuring an "empty" braking mode and one or more "loaded" braking modes, the changeover from one mode to another is done using a crank handle as shown in the above figures 1, 2, 3 or 4.

When the wagon has only a single device, it will be fitted with a lever of the kind shown in figures 1 or 2.

When the wagon has two or more separate devices, the levers are fitted with a handle as shown in figures 3 or 4.

In the "empty" braking mode, the lever slants upwards and to the left and will occupy its extreme left-hand position if:

- the wagon is empty,
- the gross weight (tare + load) is less than the changeover weight marked,
- the mass per axle or per bogie is less than half of the changeover weight marked.

In the "loaded" braking mode, in other words when the gross weight (tare + load) is greater than or equal to the changeover weight (the highest, when there are several positions), the lever slants upwards to the right and occupies the extreme right-hand position.

The positions corresponding to the other loaded braking modes are situated between these extreme positions, the braking power increasing from left to right.

## 4.3.4 Vehicles fitted with automatic load-proportional braking system

Figure 1

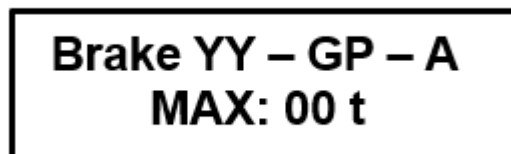

**Position:** In a box painted on each solebar.

**Meaning:** Indication of the type of brake (YY) in accordance with point 4.3.9. Additional information is also shown in point 4.3.9 (GP, A) and indication of the maximum braked weight [t] → Up to this maximum value, the braked weight [t] is equal to the sum of the wagon tare and the load [t]. This information may be preceded by the word "brake" (optional).

Figure 2

Bremse...-G-A

**Position:** On each solebar, after the brake system marking.

**Meaning:** On some older wagons, the braked weights for each load state (maximum of five) are shown as tables. Each column in the table contains two figures:

- above: →the braked weight value [t],
- below: →minimum weight on rail [t] giving a braked weight [t] at least equal to this value.

4.3.5 Vehicles fitted with an automatic "empty – loaded" changeover device

Figure 1: Vehicles featuring several braked weight values in the "goods" and "passengers" changeover

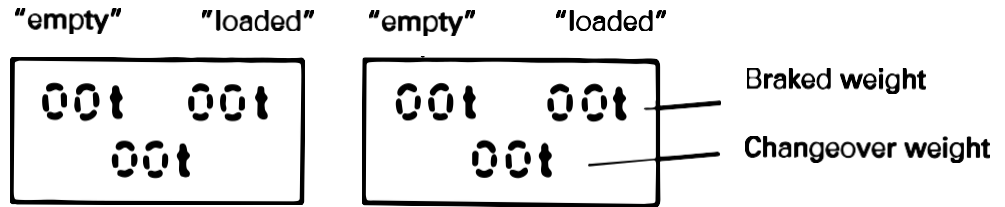

Figure 2: Vehicles featuring a single braked weight value in the "goods" and passengers" changeover

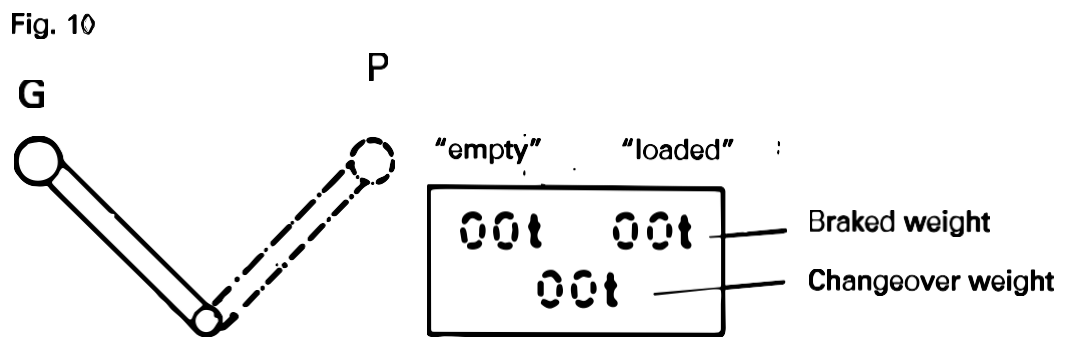
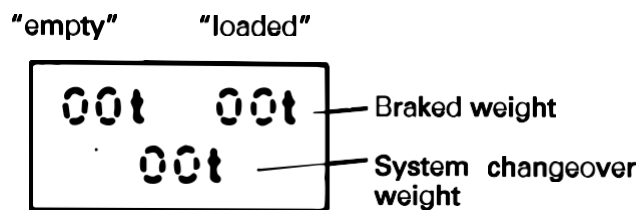

Figure 3: Vehicles featuring a "goods" brake or "passengers" brake only



**Position figures 1 – 3:** On each solebar near to the brake system marking.

**Meaning:** On these wagons, the "empty – loaded" changeover takes place automatically when the gross weight (wagon tare + load) [t] is greater than the changeover weight [t] marked.

4.3.6 Marking of the axles of wagons with a single distributor

On wagons fitted with a single brake distributor, an identification marking (serial number) can be applied to the solebar above each axle-box (optional).

## 4.3.7 Signs for wagons with more than one distributor

**a) Wagons with more than one distributor and separate "empty – loaded" changeover systems**

The braked weight [t] of the associated distributor and the changeover weight [t] for the wagon must be marked on the identification plates for each "empty – loaded" changeover device (see point 4.3.3).

**b) Wagons with several distributors and automatic load-proportional brakes**

Figure 1

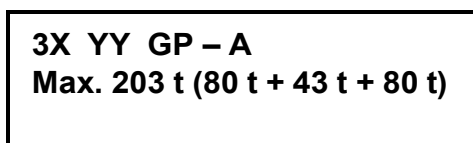
**Meaning:**

Example of markings for multiple wagons with three distributors (3X), letter code for brake type in accordance with point 4.3.9 (YY); additional letters in accordance with point 4.3.9 (GP, A).

The braked weights [t] of the corresponding distributor should be marked on the plates for each "empty – loaded" changeover device together with the changeover weight for the wagon as a whole.

Figure 2

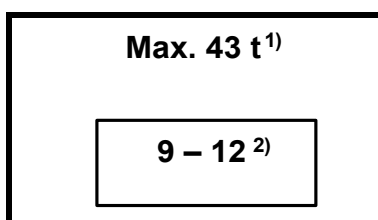
**Position of figures 1 and 2**

On each solebar near the brake isolating levers.

**Meaning:**

<sup>1)</sup> Braked weight delivered by the system controlled by the distributor in question.

<sup>2)</sup> Indication of the end numbers of the axles on which this braking system acts.

The following must also be indicated (see point 4.3.7):

- the number of brake systems,
- the total braked weight and in brackets the braked weight obtained from each distributor.

## 4.3.8 Marking of the axles of wagons fitted with several distributors and an automatic load-proportional braking system

On multiple wagons with permanent couplings fitted with several distributors and an automatic load-proportional braking system, an identification number should be marked on the solebars to indicate the corresponding position of the axle in ascending order from one end of the wagon to another. This marking must be made by 1.1.2007.

### 4.3.9 Abbreviated references for compressed air brakes accepted for international traffic as of 1.3.2005

#### 1. Brake type

Kunze-Knorr	Kk
Drolshammer	Dr
Bozic	Bo
Hildebrand-Knorr	Hik
Breda	Bd
Charmilles	Ch
Oerlikon	O
Knorr, type KE	KE
Westinghouse, type E	WE
Dako	DK
Westinghouse, type U	WU
Westinghouse, type A * (approved until 1.1.2000 for new built-wagons)	WA*
Davies and Metcalfe, Distributor DMD 3	DM
MZT HEPOS	MH
SAB-WABCO, Type SW 4/SW 4C/SW 4/3	SW
Distributor KE-483 * (In position "483" the brake meets the conditions of the CIS networks).	KE 483**
Bumar-Fablok MBF-01A, MBF-01B, MBF-02	FL

#### 2. Additional references

Freight train brake	G
Passenger train brake	P
High power brake	R
G/P changeover device	GP
P/R changeover device	PR
G/P/R changeover device	GPR
Automatic load-proportional braking system	A
Electromagnetic rail brake	Mg

**Position:** In the middle of each solebar, or on parts covering the solebar or on special boards fitted at the height of the solebars, near the changeover devices for the brake with the other brake markings.

### 4.4 Signs for wagons fitted with composite brake blocks

**Position:** On both sides of the wagon, directly to the right of the marking indicating the type of brake.

**Meaning:** Marking for vehicles fitted with composite brake blocks with a

- high coefficient of friction ('K' type block)
- medium coefficient of friction ("L" type block)
- low coefficient of friction ("LL" type block)

ivory to yellow

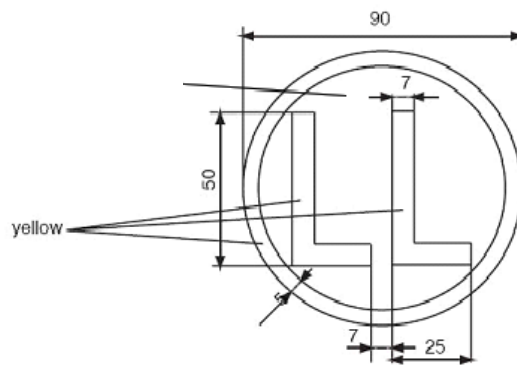
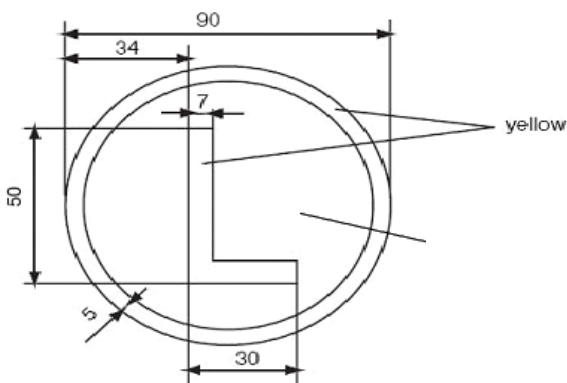
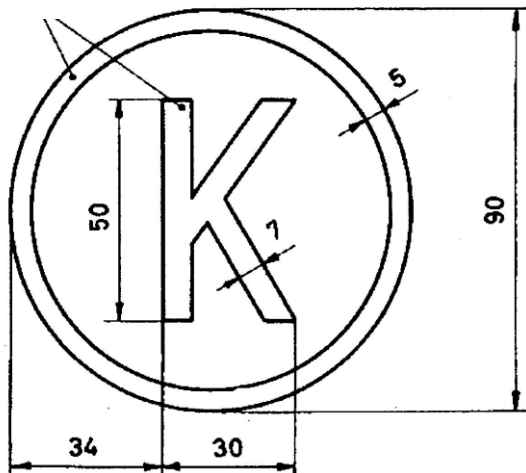

Sign(s) (e.g. C810, J816M): directly below or next to the symbol corresponding to the "K" type block. Declaration of several types of blocks possible.





#### 4.5 Sign for wagons fitted with disc brakes

Ivory to yellow

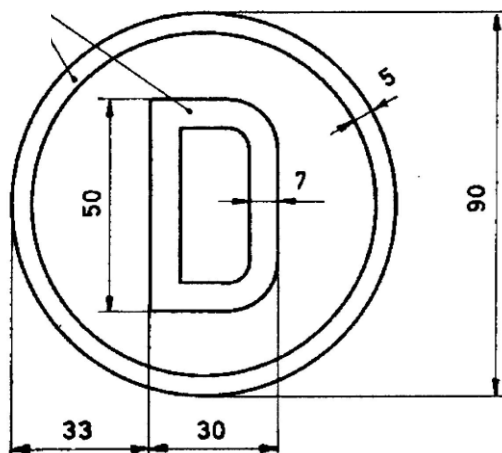

**Position:** On both sides of the wagon, directly to the right of the marking indicating the type of brake.

**Meaning:** Wagons that carry this sign are fitted with disc brakes.

**5.1 Sign for wagons not authorised to negotiate all shunting humps**

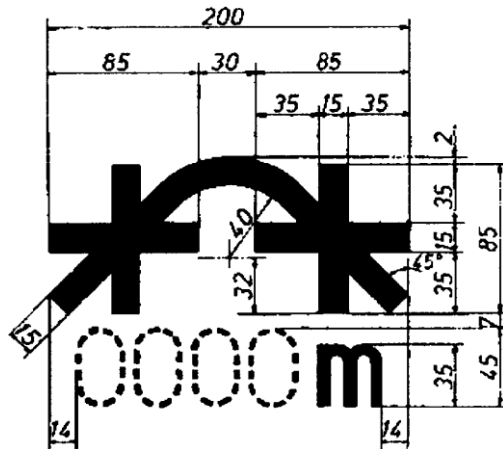

**Position:** On the left of each solebar, or on parts covering the solebar or on special boards fitted at the same height as the solebars.

**Meaning:** This marking is compulsory for wagons which, because of their design are liable to sustain damage when crossing shunting humps with a vertical radius of 250 m. The value marked indicates the smallest curve radius that the wagon can negotiate.

**5.2 Sign for bogie wagons with a distance of more than 14.0 m between inner axles and accepted on shunting humps**

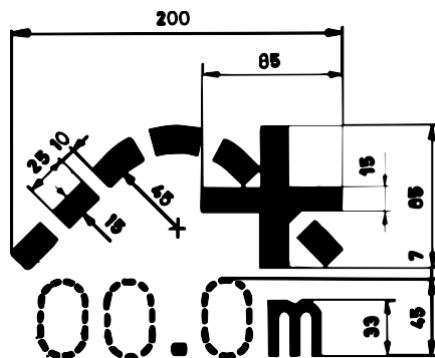

**Position:** On the left of each solebar, or on parts covering the solebar or on special boards fitted at the same height as the solebars.

**Meaning:** This marking is compulsory on bogie wagons that are suitable for crossing shunting humps, but which have a distance of more than 14.0 m between consecutive inner axles. The value indicated is the largest distance between two consecutive axles.

### 5.3 Sign for wagons that are not authorised to pass through retarders or other shunting and stopping devices in active mode

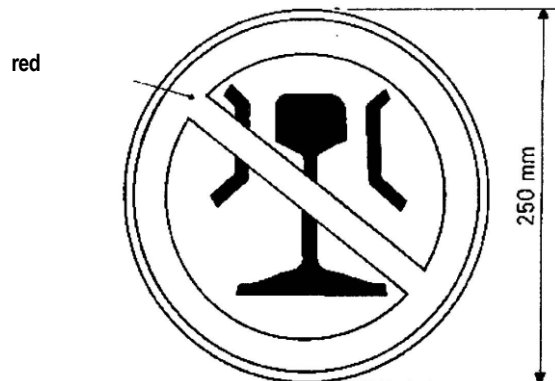

**Position:** On the left of each solebar, or on parts covering the solebar or on special boards fitted at the same height as the solebars.

**Meaning:** Because of design considerations these wagons must not pass through retarders or other types of shunting and stopping devices in active position.

### 5.4 Sign for wagons not to be loose-shunted

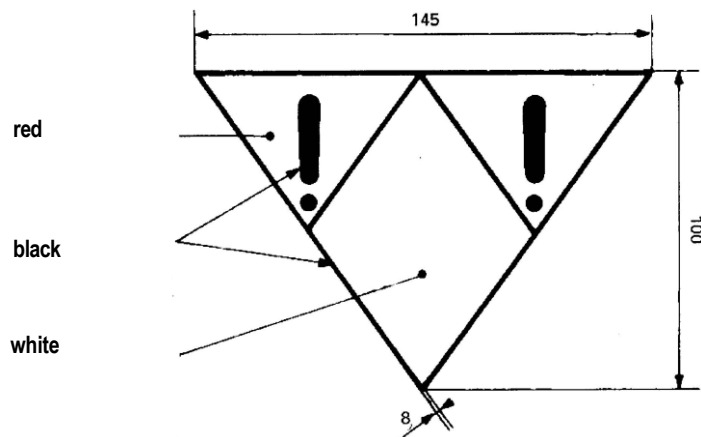

**Position:** On the left of each solebar, or on parts covering the solebar or on special boards fitted at the same height as the solebars.

**Meaning:** Special care should be taken when marshalling trains to avoid damaging the wagon. Wagon must not be loose-shunted and must be protected against buffing by other rolling stock without taking special precautions.

**Note:** This marking is compulsory on wagons with special fittings (electronic equipment, refrigerator units, etc.) for which normal buffing impacts are not authorised as they are liable to damage the equipment. These wagons may not carry the RIV sign but can be covered by bilateral agreements.

### 5.5 Sign for wagons that must not be fly- or gravity-shunted

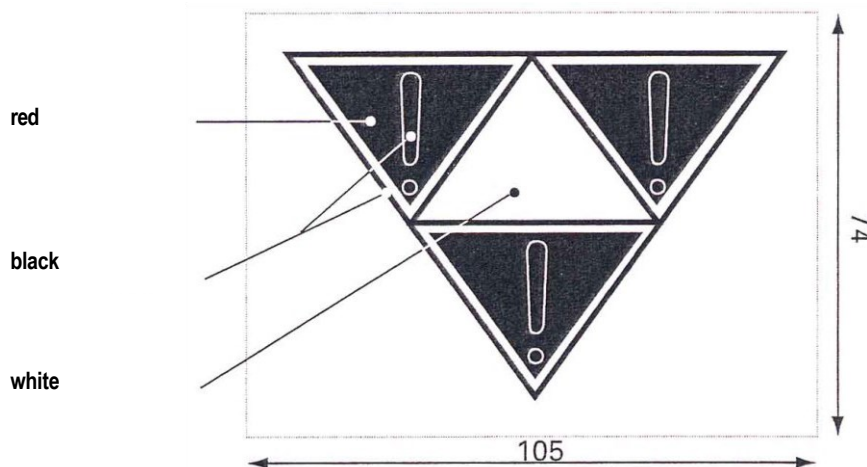

**Position:** On the left of each solebar, or on parts covering the solebar or on special boards fitted at the same height as the solebars.

**Meaning:** Wagon

- must not be fly- or gravity-shunted,
- must be marshalled by a motive power unit,
- must not be loose-shunted and must be protected against buffing by other rolling stock.

**Note:** Point 5.3.4.1 of the RID states that in place of the shunting label (shown in model 15) the wagon may instead carry permanent shunting signs (wagon markings) providing they conform precisely to the prescribed example.

### 5.6 Sign for fly and hump shunting not permitted for containers or loaded pocket wagons

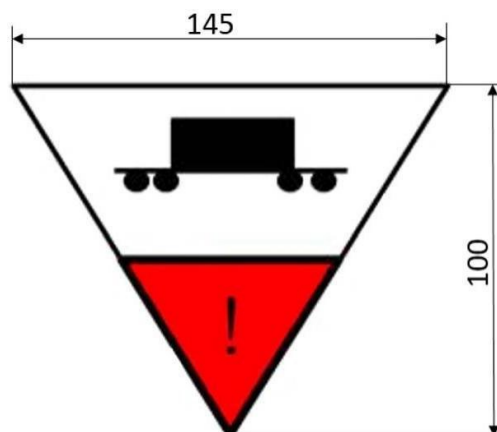

**Note:** Fly or hump shunting and buffing is not permitted when the wagon is loaded. Shunting may be performed without restriction when the wagon is empty.

## 5.7 Marking for wagons fitted with anti-crash components

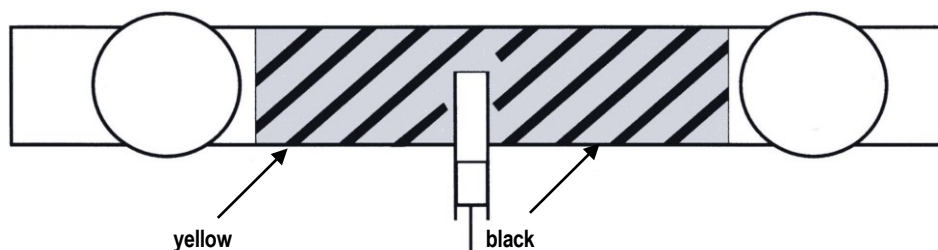

**Position:** On the headstocks, between the buffers.

**Appearance:** Paint: black diagonal warning stripes painted on a yellow background.

**Meaning:** Wagon fitted with anti-crash components. The Berne rectangle clearances may be encroached. Follow shunting instructions.

## 5.8 Marking for wagons fitted with long-stroke shock absorbers (shock absorber fitting)



Black and yellow striped surface to be left clear

**Position:** Black diagonal warning stripes painted on a yellow background covering the danger areas for wagons fitted with shock absorbers.

**Meaning:** In the event of impact, the wagon ends become displaced in relation to the underframe. Distances and clearances are reduced as a result. Particular care must therefore be taken during shunting operations.

### 5.9 Marking for wagons fitted with projecting tow hooks

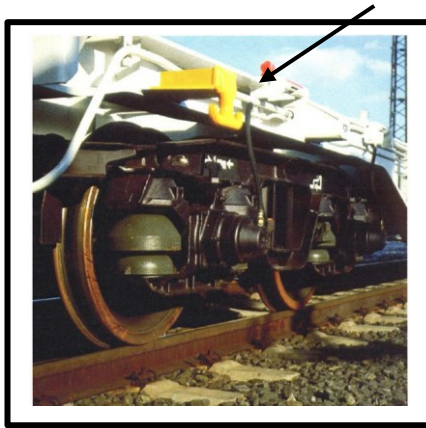

**Position:** Tow hooks and their fenders projecting more than 150 mm, and any supports and brackets, should be colour-marked as follows:

- Tow hooks and fenders: in yellow.

Colour-marking of tow hook supports and brackets:

- Projecting up to 250 mm: in yellow,
- Projecting more than 250 mm: black diagonal stripes on yellow background.

**Meaning:** Marking serving as a warning against the risk of injury.

### 5.10 Sign for permanently coupled wagon units

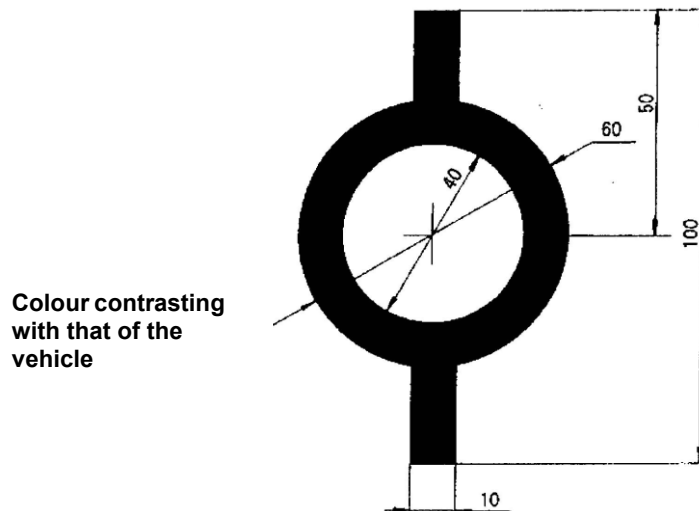

**Position:** On each headstock, next to the right-hand buffer.

**Meaning:** Not to be uncoupled in service. This sign is only used on wagons made up of several units that are permanently coupled together.

**5.11 Sign for bogie wagons only able to negotiate curves with a radius greater than 35 m**

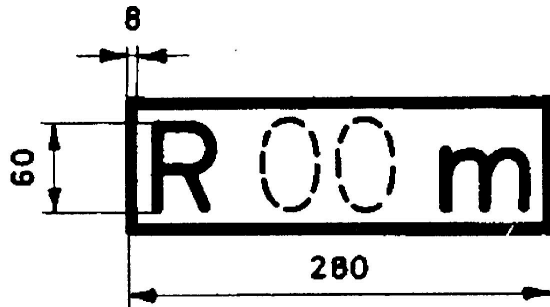

**Position:** On the left of each solebar, or on parts covering the solebar or on special boards fitted at the same height as the solebars.

**Meaning:** Indicates the minimum curve radius that the wagon can negotiate.

**Note:** On wagons with special fittings, for example low-loader wagons, this indication refers to the central position of the lateral sliding device and/or the maximum distance between bogie centres.

**5.12 Signs indicating wagons fitted with a train line**

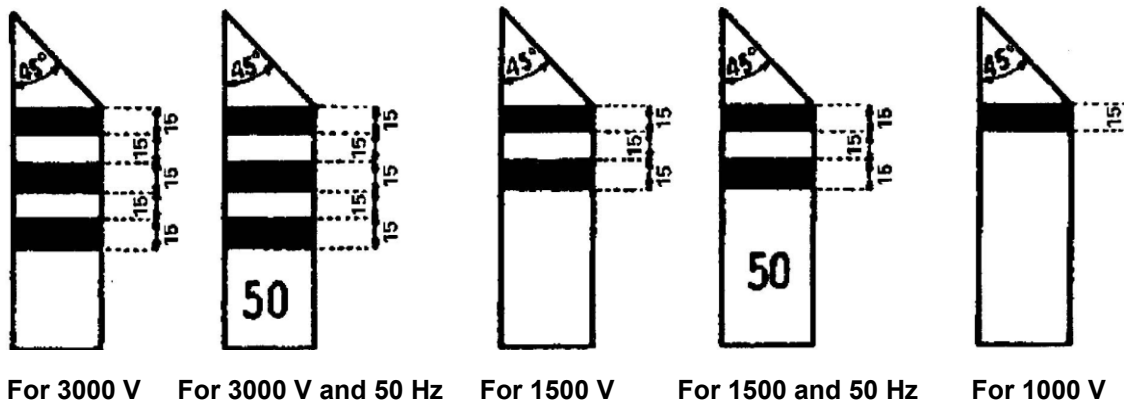

For 3000 V    For 3000 V and 50 Hz    For 1500 V    For 1500 and 50 Hz    For 1000 V

**Position:** On the lower part of the corner posts, on both outward-facing surfaces. For wagons without corner posts, it is recommended that the required markings be affixed to metal panels.

**Appearance:** Light yellow rectangle approx. 200 mm high, the same width as the corner post and with the top corner cut off at an angle of approx. 45° inclined downwards towards the centre of the wagon. Black horizontal stripes approx. 15 mm high are painted on the yellow rectangle at intervals of 15 mm.

**Meaning:** Wagon is fitted with a train line. One black stripe indicates a 1000 V DC cable, two stripes a 1500 V cable and three stripes a 3000 V cable. Approval for running on 50 Hz AC electrified networks is indicated by the number "50".

**5.13 Sign for wagons fitted with the automatic coupler**

(Sign according to OSJD\* standard)

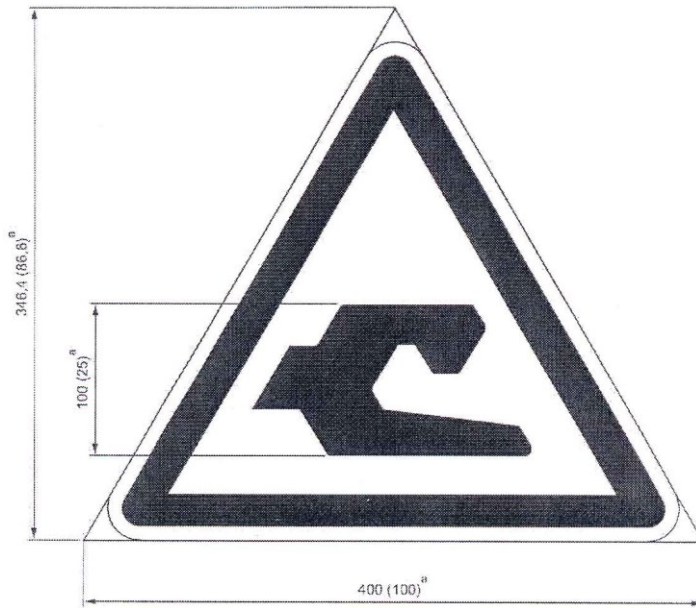

**Position:** At each end of the wagon sides or solebar and on each end wall.

**Meaning:** Wagon fitted with automatic couplers.

**Note:** On wagons fitted with the automatic coupler, the Berne rectangle clearances may be partially encroached.

\*OSJD: Organisation for Collaboration between Railways, based in Warsaw.

**5.14 Sign for derailment detectors**

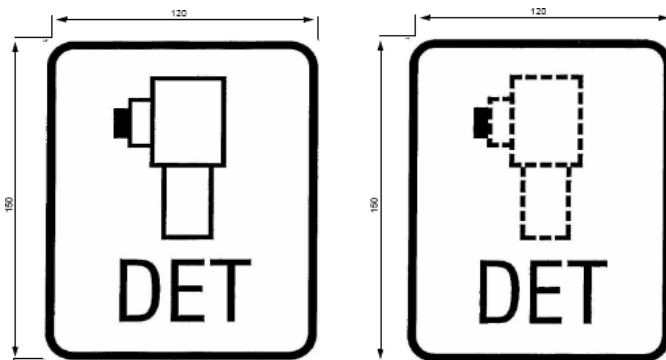

**Position:** On both sides of the wagon, when the derailment detector is visible. The picture on the sign has a dotted outline when the detector is not visible.

**Meaning:** Wagon derailment detectors are devices used to detect implausibly high vertical accelerations on the vehicle. A derailment is assumed to have taken place, and an emergency brake application is triggered or an alarm sounded. The system cannot prevent a derailment itself from occurring.



**5.15 Sign for strengthened screw coupling**

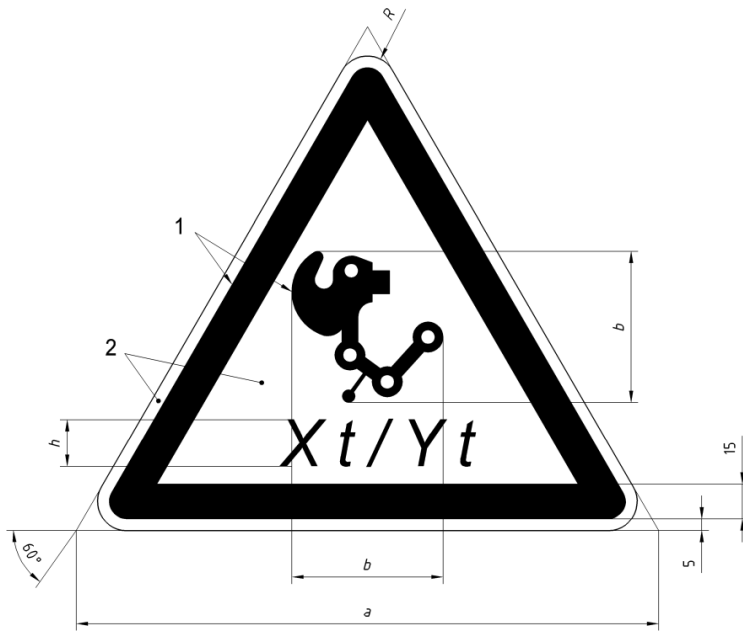

Key      1 Black  
            2 Yellow

Template	Sizes			
	a	b	h	R
1	400	130	30	22
2	200	65	20	11

**Position:** At each extremity of the side faces of the wagon or on frame girder. This marking must be chosen according to the reserved space for that purpose.

**Meaning:** Wagon with strengthened screw coupling – X t is related to coupling resistance, Y t to coupling hook. A strengthened screw coupling is described in EN 15566:2009, paragraph 4.1, Table 1. System’s recognition is over 1 MN.

– reserved –

## 6.1 Sign for wheels able to withstand high thermal stresses



Figure 1



Figure 2

**Position:** On the axle-box cover. (see figure 1)

On the axle box (see figure 2) for housing types without cover.

**Meaning:** The axles in question have wheels that are able to withstand high thermal loading, in accordance with **UIC leaflets 510-2** and **510-5**, Appendix H.

**Note:** It should be noted there are housings which, due to their design, do not have a cover. They can be recognisable by housing without holes for cover fastening.

## 6.2 Marking of tyred wheels

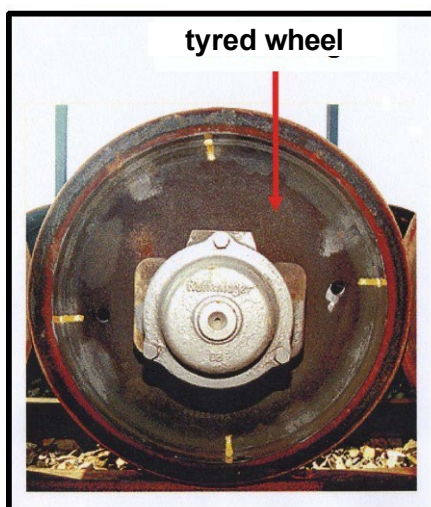

**Position:** Four coloured stripes, at 90° intervals, on the outer surface of the wheel tyre and rim.

**Meaning:** Control mark to check the position of the tyre in relation to the wheel rim.

### 6.3 Sign for ventilation pipes

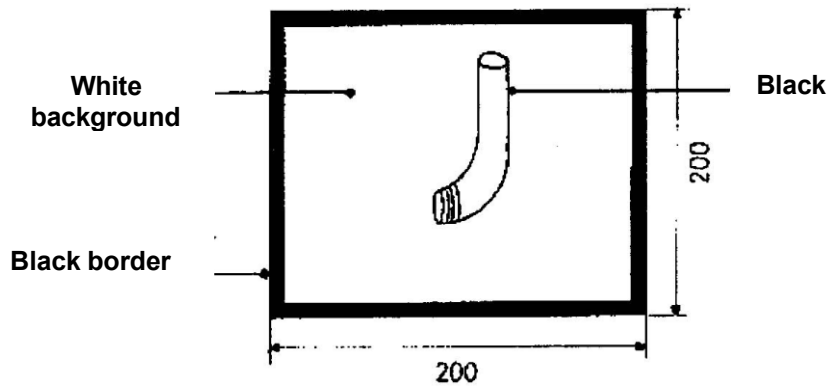

**Position:** On tanks, next to the pipes in question.

**Meaning:** The ventilation pipes marked with this symbol do not need to be sealed off completely.

### 6.4 Sign for tank wagon tests, coding of tanks and special regulations

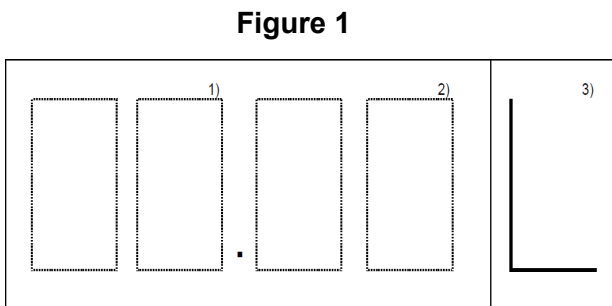

Figure 2 (example)

**TE 5**

**Position:** On each side of each tank, on the right.

**Meaning figure 1:** Indication of the next tank test (end of month) for the carriage of dangerous goods in accordance with the RID. The marking specifies 1) the month, 2) the year and if necessary, the letter “L” as per RID 6.8.2.4.3.; 3) that the date of the next tank test is extended by 3 months.

**Meaning figure 2:** Example of an alphanumerical code for all the special regulations\* applicable: here, the wagon is fitted with a highly flammable insulating material.

**\*Note:** The tank code should also be marked near the date of the tank test, in characters at least 90 mm high. The alphanumerical code for all applicable special regulations under the RID should also feature below the tank code or right beside it, in characters 50 mm high. This marking must be made by 1/1/2011 at the latest.

### 7.1 Sign indicating points for lifting the wagon body in the workshop

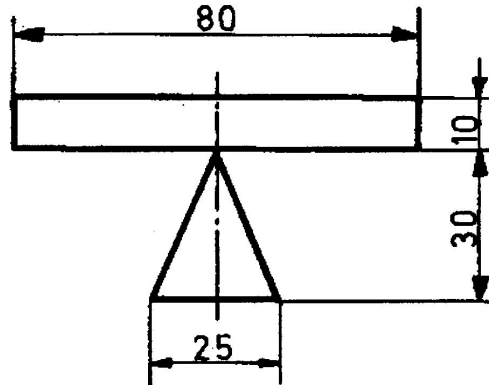

**Position:** At the designated points on the solebars.

**Meaning:** Marking indicating where to place jacks, lifting devices, etc. in order to lift the whole of the wagon body.

### 7.2 Sign for lifting at 4 points with or without running gear

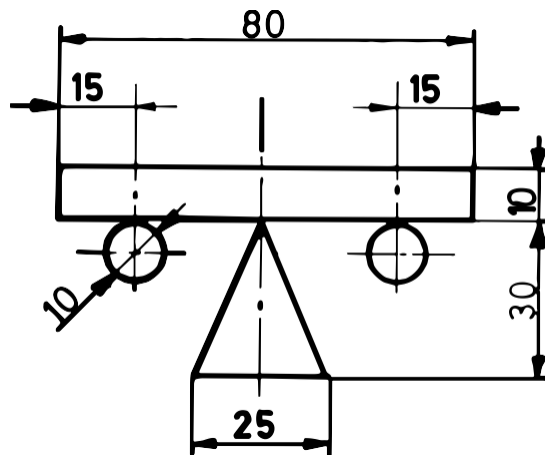

**Position:** At the designated points on the solebars.

**Meaning:** Marking indicating where to place jacks, lifting devices, etc. in order to lift the whole of the wagon body, including the running gear where appropriate.

### 7.3 Sign for lifting or re-railing with or without running gear at one end only or close to the end

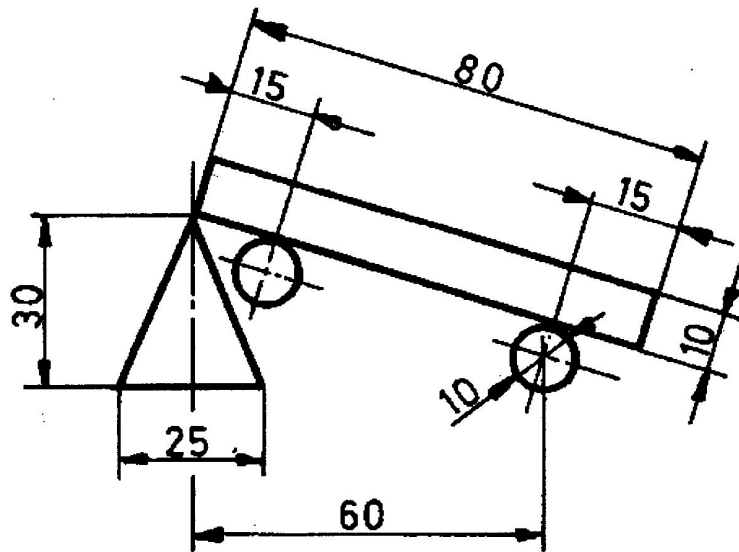

**Position:** At the designated points on the wagon headstocks or nearby.

**Meaning:** Marking indicating where to place jacks, lifting devices, etc. in order to lift the whole of the wagon body by one end, or close to the end, including the running gear where appropriate.

### 7.4 Sign for the replacement of springs

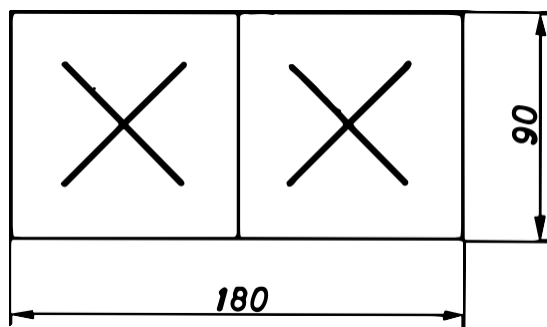

**Position:** On the right of each solebar, or on parts covering the solebar or on special boards fitted at the same height as the solebars.

**Meaning:** On wagons with a rigid underframe (tank wagons, hopper wagons, etc.), this sign indicates that if one spring is damaged, both springs must be replaced. This does not apply to suspension springs with progressive stiffness (e.g. parabolic springs). See also point 2.10, chapter A of GCU **Appendix 10**.

### 7.5 Sign for wheel tyre inspection

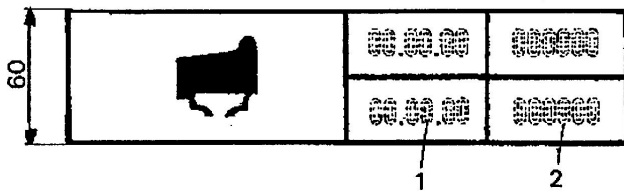
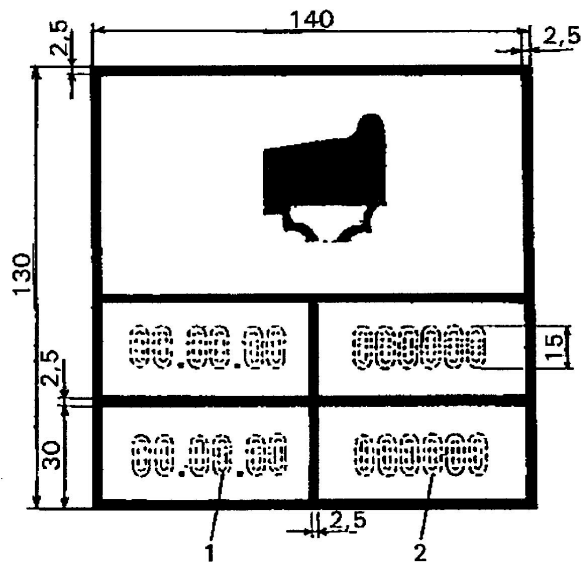

**Position:** On the right of each solebar, or on parts covering the solebar or on special boards fitted at the same height as the solebars.

**Meaning:** This plate indicates the date (day, month and year) (1) of the last two checks to ensure the tyre is firmly in place on the wheel body. In addition to the date, the initials of the RU and the code number of the workshop are also specified (2).

## 7.6 Sign for inspection periods for temperature-controlled units



(Blue characters on a white background)

**Position:** On the right of each side wall, beneath the UIC or UIC St sign.

**Meaning:** On wagons used to carry perishable foodstuffs, this sign shows the distinguishing mark for the temperature control system under the ATP agreement and indicates the expiry date (month and year) of the certificate held by the wagon.

## 7.7 Sign for the protection of the inner lining of tank wagons

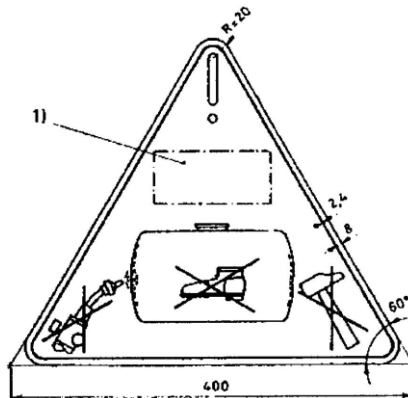

(Paint: Black outline and markings on a yellow background)

**Position:** On the tank at clearly visible points

**Meaning:** Precautions designed to protect the inner lining (enamel, coat of paint, etc.).

**Note:** The words "inner lining" may be added to this pictogram in one or more languages.



**7.8 Signs for privately-owned wagons, unified wagons, standard wagons**

Figure 1: Sign for privately-owned wagons (registered with an RU before the GCU entered force)

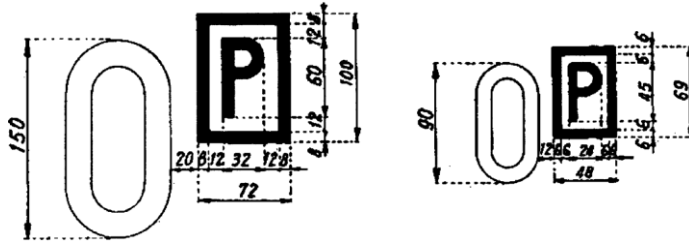

**Position:** On the left of each side wall, after the wagon self-check digit.  
 Marking: if there is no room on the left, the name or company and initials of the wagon keeper may be marked on the right-hand side.

**Meaning:** Privately-owned wagons, registered by their keepers with an RU. The keeper's name or company and initials should also be indicated (together with its fax number). This marking will be cancelled in the future.

Figure 2: Sign for unified wagons

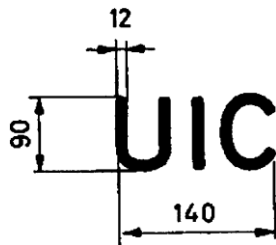

**Position:** On the right of each side wall.

**Meaning:** Wagon meeting standard international regulations (unified wagons).

Figure 3: Sign for standard wagons

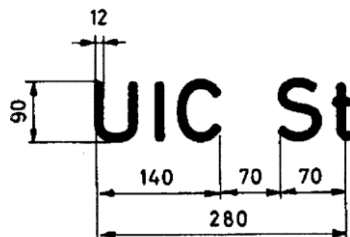

**Position:** On the right of each side wall.

**Meaning:** Only unified wagons built in accordance with ERRI drawings (standard wagons) may carry this marking.

## 7.9 Markings for certain spare parts

- 7.9.1 Standard screw couplers carry the "St" marking.
- 7.9.2 Wheelsets suitable for axle-loads of more than 20.0 tonnes carry the sign 2Q= 00.0 t indicating the permissible axle-load:
- either on the identification ring for wheelsets
  - or on the inner face of the wheel hub for wheelsets
- 7.9.3 Suspension leaf springs suitable for axle-loads of more than 20.0 tonnes carry the sign 2Q = 00.0 t on the shackle, indicating the permissible axle-load.
- 7.9.4 When welding or heating work on or near the wagon buffers can constitute an accident hazard, a yellow disc of 50 mm diameter should be painted on the buffer casing.
- 7.9.5 For standard buffers with a stroke of 105 mm, the sign 105 – X shall be marked on the buffer casing the owner's mark to indicate the buffer stroke and buffer category (A, B or C) as defined in the UIC Code. Buffers manufactured before 1/1/1981 that do not meet the conditions of category A do not feature the category letter.

## 8.1 Sign for high voltage warning sign (lightning flash)

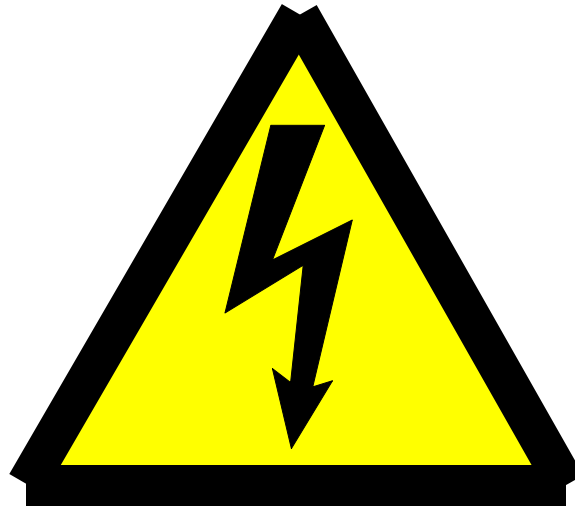

**Position:** On wagons fitted with steps or ladders, in the immediate vicinity of these fittings and at a height such that the sign is visible before the danger zone is reached. For use on wagons where the top step or upper part of the ladder is more than 2000 mm above rail level.

**Meaning:** Warning against high voltage. Stop! You are entering a particularly dangerous area. Only duly authorised personnel may work in this area having first taken the necessary precautions.

**Note:** The size of the sign will depend on where it is to be placed.

## 8.2 Signs for high voltage warning sign (Stop!)



**Position:** On wagons with steps or ladders, in the immediate vicinity of these fittings and at a height such that the sign is visible before the danger zone is reached. For use on wagons where the top step or upper part of the ladder is more than 2.0 m above rail level, or whose design enables them to be climbed.

This pictogram may be shown on a rectangular blue background measuring 400 mm x 220 mm.

**Meaning:** Warning - high voltage. Stop! You are entering a particularly dangerous area. Only duly authorised personnel may work in this area having first taken the necessary precautions.

**Note:** This marking is mandatory as of 1/1/2021.

**Explanation:** This pictogram is intended to warn inspection personnel and unauthorised third parties of the risk of high voltage on the wagon.

Wagons whose design enables them to be climbed fulfil two criteria:

1. The external part of the end walls is fitted with horizontal elements with a maximum vertical distance of 45 cm.
2. These elements must be at least 5 cm in depth or must be comparable to steps of a ladder.

If both criteria are fulfilled, the pictogram in 8.2, “Signs for high voltage warning sign (Stop!)” must be affixed, but the pictogram in 8.1, “Sign for high voltage warning sign (lightning flash)” is not required.

Both warning pictograms (8.1 and 8.2) must be affixed on wagons equipped with ladders and steps.